

# SOLAN DECOMMISSIONING

## Pipeline Comparative Assessment

### Consultation Draft

|   |                               |
|---|-------------------------------|
| <b>Document No.</b>   | AB-SO-LAP-LL-SU-RP-0001       |
| <b>Revision</b>   | B01                           |
| <b>Status</b>   | Issued for Use (Consultation) |
| <b>Legacy Documents</b>   | N/A                           |
| <b>Alternative Document Number</b>  | N/A                           |
| <b>Total Number of Pages (Incl. Cover Page)</b>   | 65                            |
| This document contains proprietary information belonging to Premier Oil and must not be wholly or partially reproduced nor disclosed without prior written permission from Premier Oil.<br>The master copy of this document is held electronically within Premier Oil's Document Management System. If you are using a paper copy or a digital issue of this document, it is your responsibility to ensure it is the latest version |                               |

## **Approvals**

| <b>Prepared by</b> | <b>Name</b>       | <b>Date</b> |
|--------------------|-------------------|-------------|
| Prepared by        | S. Axon           | 24/05/24    |
| Reviewed by        | P. voor de Poorte | 24/05/24    |
| Approved by        | M. Burnett        | 24/05/24    |

## **Revision Control**

| <b>Revision</b> | <b>Reference</b>              | <b>Changes / Comments</b>                       | <b>Issue date</b> |
|-----------------|-------------------------------|---|-------------------|
| A01             | Internal review               | First issue                                     | 27/09/22          |
| A02             | Issued to OPRED for review    | Amended as per internal feedback                | 18/10/22          |
| A03             | Issued to OPRED for review    | Amended as per internal feedback                | 31/01/23          |
| B01             | Issued for Use (Consultation) | Schematics updated ("Leg" changed to "Loading") | 24/05/24          |
|                 |                               |   |                   |

## **Distribution List**

| <b>Organisation</b>    | <b>No of Copies</b> |
|------------------------|---------------------|
| OPRED                  | 1 electronic        |
| NFFO, NIFPO, SFF & GMG | 1 electronic        |
|                        |                     |
|                        |                     |

## Table of Contents

|  |           |
|--|-----------|
| <b>Approvals .....</b>   | <b>3</b>  |
| <b>Revision Control.....</b>   | <b>3</b>  |
| <b>Distribution List .....</b>   | <b>3</b>  |
| <b>Figures and Tables .....</b>  | <b>6</b>  |
| <b>Table of Abbreviations .....</b>  | <b>7</b>  |
| <b>1 EXECUTIVE SUMMARY .....</b>   | <b>9</b>  |
| <b>1.1 Overview .....</b>  | <b>9</b>  |
| <b>1.2 Pipelines, Flowlines, and Umbilicals.....</b>   | <b>10</b> |
| 1.2.1 Decommissioning Options.....   | 10        |
| 1.2.2 Method .....   | 10        |
| 1.2.3 Conclusion .....   | 10        |
| 1.2.4 Recommendations.....   | 11        |
| <b>2 INTRODUCTION.....</b>   | <b>13</b> |
| <b>2.1 Overview .....</b>  | <b>13</b> |
| <b>2.2 Solan Area layout.....</b>  | <b>14</b> |
| <b>2.3 Purpose .....</b>   | <b>15</b> |
| <b>2.4 Environmental setting.....</b>  | <b>15</b> |
| 2.4.1 Overview.....  | 15        |
| 2.4.2 Protected Areas .....  | 16        |
| 2.4.3 Commercial Activities - Fishing.....   | 17        |
| 2.4.4 Commercial Activity – Vessel Traffic .....   | 18        |
| 2.4.5 Sandbags.....  | 19        |
| 2.4.6 Mattresses .....   | 19        |
| 2.4.7 Deposited Rock.....  | 20        |
| <b>2.5 Assumptions, Limitations, and gaps in Knowledge .....</b>   | <b>21</b> |
| <b>3 THE PIPELINES, UMBILICALS AND CABLES.....</b>   | <b>22</b> |
| <b>3.1 Overview .....</b>  | <b>22</b> |
| <b>3.2 Pipeline Exposure &amp; Spans .....</b>   | <b>22</b> |
| <b>3.3 Pipeline Crossings .....</b>  | <b>23</b> |
| <b>3.4 Pipeline Crossing Summary .....</b>   | <b>23</b> |
| <b>3.5 The SOST Pipelines, Flowlines and Umbilicals .....</b>  | <b>23</b> |
| 3.5.1 PL3094 24in Tank Displacement Pipeline, Solan Platform to SOST.....                                | 23        |
| 3.5.2 PL3095 24/20in Oil Export Pipeline & Offloading Hose, SOST to Offloading Connection.....           | 24        |
| 3.5.3 PL3578 10in Oil Export Flowline, Solan Platform to SOST.....                                       | 25        |
| 3.5.4 PL3579 12in Water Ballast Flowline, SOST to Solan Platform .....                                   | 25        |
| 3.5.5 PLU3584 SOST Control Umbilical, Solan Platform to SOST .....                                       | 25        |
| <b>3.6 The DC1 and DC2 Pipelines, Flowlines and Umbilicals.....</b>                                      | <b>25</b> |
| 3.6.1 PL3580 Well P1 6in Production Flowline, Well P1 to Solan Platform .....                            | 25        |
| 3.6.2 PL3581 Well P2 6in Production Flowline, Well P2 to Solan Platform .....                            | 25        |
| 3.6.3 PL3582 Well W1 6in Water Injection Flowline, Solan Platform to Well W1 .....                       | 25        |
| 3.6.4 PL3583 Well W2 6in Water Injection Flowline, Solan platform to Well W2 .....                       | 26        |
| 3.6.5 PLU3585 Well P1 Control Umbilical, Solan Platform to Well P1 .....                                 | 26        |
| 3.6.6 PLU3586 Well P2 Control Umbilical, Solan Platform to Well P2 .....                                 | 26        |
| 3.6.7 PLU3585JW2 Well W2 Control Umbilical Jumper, Well P1 to Well W2 .....                              | 26        |
| 3.6.8 PLU3586JW1 Well W1 Control Umbilical Jumper, Well P2 to Well W1 .....                              | 26        |
| 3.6.9 PLU4204 Replacement Electrical Umbilical, SUTU to Umbilical Junction Box 1 .....                   | 27        |
| 3.6.10 PLU4205 Well P2 Replacement Electrical Umbilical Jumper, Umbilical Junction Box 1 to Well P2..... | 27        |

|                   |   |           |
|-------------------|---|-----------|
| 3.6.11            | PLU4206 Well W1 Replacement Electrical Umbilical Jumper, Umbilical Junction Box 1 to Well W1...   | 27        |
| 3.6.12            | PLU4207 Replacement Electrical Umbilical, SUTU to Umbilical Junction Box 2 .....                  | 27        |
| 3.6.13            | PLU4208 Well P2 Replacement Electrical Umbilical Jumper, Umbilical Junction Box 2 to Well P2..... | 27        |
| 3.6.14            | PLU4209 Well W1 Replacement Electrical Umbilical Jumper, Umbilical Junction Box 2 to Well W1...   | 27        |
| <b>3.7</b>        | <b>The Well P3 Flowlines and umbilicals.....</b>  | <b>27</b> |
| 3.7.1             | PL4971 Well P3 6in Flexible Flowline, Well P3 to Well P1 .....                                    | 27        |
| 3.7.2             | PLU4972 Well P3 Control Umbilical, Solan Platform to Well P3 SUTU .....                           | 27        |
| 3.7.3             | PL4973 Well P3 1in Electrical Fly Lead, Well P3 SUTU to Well P3 .....                             | 28        |
| 3.7.4             | PL4974 Well P3 1in Electrical & Communications Fly Lead, Well P3 SUTU to Well P3 .....            | 28        |
| 3.7.5             | PL4975 Well P3 2in Electrical & Communications Fly Lead, Well P3 SUTU to Well P3 .....            | 28        |
| 3.7.6             | PLU4976 Well P3 6in Hydraulic Fluids Fly Lead, Well P3 SUTU to well P3 .....                      | 28        |
| 3.7.7             | PL4977 Well P3 1in Electrical & Communications Fly Lead, Well P3 SUTU to Well P3 .....            | 28        |
| <b>4</b>          | <b>DECOMMISSIONING OPTIONS .....</b>  | <b>29</b> |
| <b>4.1</b>        | <b>Pipelines.....</b>   | <b>29</b> |
| <b>5</b>          | <b>COMPARATIVE ASSESSMENT METHODOLOGY .....</b>   | <b>31</b> |
| <b>6</b>          | <b>COMPARATIVE ASSESSMENT.....</b>  | <b>34</b> |
| <b>6.1</b>        | <b>Technical Considerations.....</b>  | <b>34</b> |
| <b>6.2</b>        | <b>Safety Considerations .....</b>  | <b>34</b> |
| <b>6.3</b>        | <b>Environmental Considerations.....</b>  | <b>37</b> |
| <b>6.4</b>        | <b>Societal Conditions .....</b>  | <b>40</b> |
| <b>6.5</b>        | <b>Cost considerations.....</b>   | <b>40</b> |
| <b>7</b>          | <b>CONCLUSIONS AND RECOMMENDATIONS .....</b>  | <b>42</b> |
| <b>7.1</b>        | <b>Conclusions .....</b>  | <b>42</b> |
| <b>7.2</b>        | <b>Recommendations .....</b>  | <b>43</b> |
| <b>8</b>          | <b>REFERENCES.....</b>  | <b>44</b> |
| <b>APPENDIX A</b> | <b>FLOWLINE AND UMBILICAL CONSTRUCTION.....</b>   | <b>45</b> |
| Appendix A.1      | Flowline construction .....   | 45        |
| Appendix A.2      | SOST umbilical (PLU3584).....   | 45        |
| Appendix A.3      | DC1 & DC2 umbilicals (PLU3585 & PLU3586) .....  | 46        |
| Appendix A.4      | Well P3 umbilical PLU4972 .....   | 47        |
| Appendix A.5      | Well P3 6in hydraulic fluid fly-lead PLU4976.....   | 48        |
| <b>APPENDIX B</b> | <b>SCHEMATICS.....</b>  | <b>49</b> |
| Appendix B.1      | Overview .....  | 49        |
| Appendix B.2      | Solan platform .....  | 50        |
| Appendix B.3      | Solan platform & SOST .....   | 51        |
| Appendix B.4      | Single Anchor Loading (SAL) approach .....  | 52        |
| Appendix B.5      | DC1 (wells P1 & W2) & DC2 (wells P2 & W1) .....   | 53        |
| Appendix B.6      | Well P3 .....   | 54        |
| <b>APPENDIX C</b> | <b>PIPELINES CA TABLES.....</b>   | <b>55</b> |
| Appendix C.1      | Technical Assessment .....  | 55        |
| Appendix C.2      | Safety Assessment .....   | 57        |
| Appendix C.3      | Environmental Assessment .....  | 59        |
| Appendix C.4      | Societal Assessment.....  | 61        |
| Appendix C.5      | Cost Assessment .....   | 62        |
| <b>APPENDIX D</b> | <b>PIPELINE COST ASSESSMENT.....</b>  | <b>63</b> |
| Appendix D.1      | Overview .....  | 63        |

|                     |                                       |           |
|---------------------|---------------------------------------|-----------|
| <b>Appendix D.2</b> | <b>Assumptions</b> .....              | <b>63</b> |
| <b>Appendix D.3</b> | <b>Cost by Difference Table</b> ..... | <b>65</b> |

## **Figures and Tables**

|   |    |
|---|----|
| Figure 2.2.1: Overview of Solan location.....   | 14 |
| Figure 2.2.2: Overview of Solan infrastructure .....  | 15 |
| Figure 2.4.1: Locality of the Solan installations and infrastructure in relation to MPAs.....   | 16 |
| Figure 2.4.2: Value of fish landings as a percentage of UK fishing effort.....                  | 17 |
| Figure 2.4.3: Landed fish value for ICES 49E5, 49E6, 48E5 & 48E6 .....                          | 18 |
| Figure 2.4.4: Value per km <sup>2</sup> for fish landed from ICES 49E5, 49E6, 48E5 & 48E6 ..... | 18 |
| Figure 2.4.5: Maritime Vessel Weekly AIS Tracking Data, 2017 [1] .....                          | 19 |
| Figure 3.3.1: Over/under convention for pipeline crossings.....                                 | 23 |
| Figure 3.5.1: PL3095 lower and upper hose sections at SAL.....                                  | 24 |
| Figure 3.5.2: PL3095 profile of deposited rock, 204m long x 20m wide .....                      | 24 |
| Figure A.1.1: Typical construction of flexible flowline .....                                   | 45 |
| Figure A.2.1: SOST umbilical PLU3584 construction (146mm diameter) .....                        | 45 |
| Table 2.4.1: Scottish Marine Protected Areas / Special Protection Areas .....                   | 17 |
| Table 2.4.2: Solan deposited rock summary .....   | 20 |
| Table 3.1.1: Solan pipeline, flowline, and umbilical summary .....                              | 22 |
| Table 3.4.1 Solan pipeline, flowline, and umbilical crossings.....                              | 23 |
| Table 4.1.1: Decommissioning the pipelines, flowlines, and umbilicals .....                     | 30 |
| Table 4.1.1: Pipelines comparative assessment method – criteria & sub-criteria .....            | 33 |
| Table 6.2.1 Quantity recovered for each option and (likely) method.....                         | 36 |
| Table 6.3.1 Area of seabed disturbed during recovery operations (short-term).....               | 38 |
| Table 6.3.2 Area of seabed disturbed during recovery operations (long-term) .....               | 39 |
| Figure A.3.1: DC1 & DC2 umbilicals PLU3585 & PLU3586 construction .....                         | 46 |
| Figure A.4.1: Well P3 umbilical PLU4972 construction .....                                      | 47 |
| Figure A.5.1: Well P3 hydraulic fly-lead PLU4976 construction .....                             | 48 |
| Figure B.1.1: Overview of infrastructure in Solan development area.....                         | 49 |
| Figure B.2.1: Pipelines, flowlines & umbilicals at the Solan platform.....                      | 50 |
| Figure B.3.1: Pipelines, flowlines & umbilicals between Solan platform & SOST .....             | 51 |
| Figure B.4.1: PL3095 at SAL .....   | 52 |
| Figure B.5.1: Layout at DC1 (wells P1 & W2) and DC2 (wells P2 & W1).....                        | 53 |
| Figure B.6.1: Layout at well P3 .....   | 54 |
| Table C.1.1: PL3095 - technical assessment .....  | 55 |
| Table C.1.2: Flowlines and umbilicals - technical assessment.....                               | 56 |
| Table C.2.1: PL3095 – safety assessment .....   | 57 |
| Table C.2.2: Flowlines and umbilicals – safety assessment.....                                  | 58 |
| Table C.3.1: PL3095 – environmental assessment .....  | 59 |
| Table C.3.2: Flowlines and umbilicals – environmental assessment.....                           | 60 |
| Table C.4.1: PL3095 – societal assessment.....  | 61 |
| Table C.4.2: Flowlines and umbilicals - societal assessment.....                                | 61 |
| Table C.5.1: PL3095 – cost assessment .....   | 62 |
| Table C.5.2: Flowlines and umbilicals - cost assessment.....                                    | 62 |
| Table D.1.1: Categories of impact – cost assessment .....                                       | 63 |
| Table D.3.1: Pipeline cost by difference assessment (& normalised) .....                        | 65 |

## **Table of Abbreviations**

| <b>Table of Abbreviations</b> |   |
|-------------------------------|---|
| <b>Abbreviation</b>           | <b>Description</b>  |
| ~                             | Approximately   |
| 3LPP                          | 3-Layer polypropylene coating used for carbon steel pipelines and pipework  |
| approaches                    | Refer to pipelines, flowlines, and umbilicals as they come nearer to the installations or pipeline structures.  |
| CA                            | Comparative Assessment  |
| cut and lift                  | The 'cut and lift' method of removing trenched and buried pipelines would involve excavating the pipelines from within the seabed and thereafter cutting the pipeline in to recoverable and transportable lengths. The method is usually only viable for short pipelines. |
| CWC                           | Concrete Weight Coated (thickness varies between 40mm and 45mm), applies to PL1225 and part of PL1226 only. It is typically used to provide on-bottom stability and for pipelines that are surface laid it provides protection against impacts from fishing gear.         |
| DC1, DC2                      | Drill Centre 1 (Well P1 & W1), Drill Centre 2 (Well P2 & W2)  |
| flexible flowline             | Flexible pipeline constructed with layers of various materials including steel and plastics typically used to transport products from production wells or to water injection wells.   |
| FPSO                          | Floating Production, Storage and Offloading (vessel)  |
| HAZID                         | Hazard Identification   |
| ICES                          | The International Council for the Exploration of the Sea.   |
| ICES rectangle                | ICES divides the sea into ICES divisions for statistical purposes. Rectangle 45F1 covers an area 3,270km <sup>2</sup> .   |
| ID                            | Identifier. Usually a number provided by the North Sea Transition Authority for pipelines, umbilicals (and electrical cables).  |
| infrastructure                | Includes and all pipelines and umbilicals associated with the Solan development.  |
| Junction Box                  | Splitter junction box used to connect the replacement electrical umbilicals PLU4204 through PLU4209   |
| KP                            | Kilometre Point, usually measured from point of origin, the start of the pipeline at the pipeline flange. A negative KP means that the features (e.g. tie-in spools) lie between the riser flange and the start of the pipeline.  |
| LAT                           | Lowest Astronomical Tide  |
| m                             | metre, 1000mm   |
| MFE                           | Mass Flow Excavator provides a method of clearing sediment material from buried objects.  |
| mm                            | millimetre  |
| MM                            | Millions (Table D.3.1)  |
| MPA, SMPA                     | Marine Protected Area, Scottish Marine Protected Area   |
| NPT                           | Non-Productive Time   |
| NSTA                          | North Sea Transition Authority  |
| OPRED                         | Offshore Petroleum Regulator for Environment and Decommissioning  |
| pipeline(s)                   | Collective term for pipeline, flowline, umbilical or fly-lead   |
| PL, PLU                       | Pipeline or Umbilical Identification number as given by NSTA using the PWA application process  |
| platform                      | Installation, typically comprising topsides and substructure such as a jacket or legs   |
| Premier Oil                   | Premier Oil UK Limited  |

| Table of Abbreviations |   |
|------------------------|---|
| Abbreviation           | Description   |
| PWA                    | Pipeline Works Authorisation  |
| risk                   | Defined by the Institution of Civil Engineers as being either an ‘opportunity’ or ‘threat’. In this report the word “risk” is used to describe a “threat”.  |
| ROV                    | Remotely Operated Vehicle   |
| SAL                    | Single Anchor Loading   |
| SOST                   | Subsea Oil Storage Tank   |
| SPA                    | Special Protection Area   |
| S-lay                  | A pipelay method whereby sections of pipe are welded together on a horizontal deck, their transition down to seabed taking the form of an elongated “S”   |
| SUTU                   | Subsea Umbilical Termination Unit, located at DC1 (adjacent to well P1) or at well P3 where noted.  |
| UKCS                   | United Kingdom Continental Shelf  |
| UMBJB1, UMBJB2         | Umbilical Junction Box 1, Umbilical Junction Box 2. Both are located near DC2 and can be described as umbilical splitters that are integral with the umbilical(s) rather than junction boxes.   |
| umbilical              | Flexible pipeline manufactured of various materials including steel and plastics typically used to send electrical power, communication signals, chemicals and hydraulic fluid to a manifold or wellhead. An umbilical will include cables and tubes that are covered with an outer sheath – usually manufactured from synthetic materials to protect them from damage. |
| x                      | Number, e.g. 9x = 9 of or number, or used to link dimensions of an object (Length, x Width, x Height)   |



# **1 EXECUTIVE SUMMARY**

## **1.1 Overview**

A comparative assessment of the pipelines, flowlines, umbilicals, and cables is a key consideration within the Solon Hub Decommissioning Programmes submitted to the Offshore Petroleum Regulator for Environment and Decommissioning (OPRED).

The Solon field is in the Northern North Sea in United Kingdom Continental Shelf block 205/26a. It is situated to the north of Scotland approximately 134km north-north-west of Kirkwall in the Orkney Islands and ~158.8km west of Lerwick in the Shetland Islands. The water depth at the Solon platform is ~136m relative to Lowest Astronomical Tide (LAT).

The Solon facilities comprise a surface installation, a subsea oil storage tank (SOST), and a Single Anchor Loading (SAL) oil offloading system. Crude oil is stored in the SOST before periodically being offloaded to a tanker via a SAL. The Solon development has been producing hydrocarbons since 2016. It was developed in two phases with the Drill Centres DC1 and DC2 being completed in 2013, followed by well P3 in 2020. Production wells P1 and P2 are supported by water injection wells W2 and W1 respectively. The three production wells P1, P2 and P3 are supported by water injection wells W2 and W1.

Production wells P1 and P2 each export directly to the Solon platform using 268mm diameter flexible flowlines PL3580 and PL3581 respectively. The Solon platform provides seawater for water injection to well W1 and W2 using 268mm diameter flexible flowlines PL3582 and PL3583. The Solon platform also provides electrical power, chemicals, and hydraulic fluids to well P1 and well P2 using 176mm diameter umbilicals PLU3585 and PL3586 respectively and using umbilical jumpers PLU3585JW2 and PLU3586JW1 controls to W2 (nearest well P1) and W1 (nearest well P2) via the Subsea Umbilical Termination Unit (SUTU) near DC1. The electrical and communication components of both PL3586 and PL3586JW1 were found to be damaged and so these were disconnected and replaced by PLU4204, PLU4205, PLU4206, PLU4207, PLU4208 and PLU4209.

Using 244mm diameter flexible flowline PL4971, production from well P3 is sent to well P1 and onwards to the Solon platform. The controls for the well P1 wing valve and the electrical submersible pump serving well P3 are interlocked so that production from P1 and P3 to Solon cannot occur simultaneously. The Solon platform provides electrical power, chemicals, and hydraulic fluids to well P3 using PLU4972 (205mm) that is routed to the SUTU next to P3. From there, they are distributed to the various connection points at the well using several umbilical jumpers and fly leads (PL4973 (25mm), PL4974 (25mm), PL4975 (56mm), PLU4976 (157mm) and PL4977 (25mm)).

The produced crude oil is exported from the Solon platform to the Subsea Oil Storage Tank (SOST) using PL3578 which is a 368mm flexible flowline. As oil accumulates in the SOST, the ballast water is displaced back to the platform using PL3579 (390mm flexible flowline). Periodically, crude oil is exported from the SOST to an oil tanker via the SAL using the displacement method. This involves pumping seawater from the Solon platform using PL3094 (24in concrete coated pipeline) into the SOST, forcing the oil out of the storage tank towards the tanker using PL3095. PL3095 comprises three parts: a 24in concrete coated pipeline between the SOST and the SAL and 20in lower and upper hoses between the SAL and the tanker connection. Solon provides electrical power, chemicals, and hydraulic fluids to the control valves at the SOST using 148mm diameter umbilical PLU3584.

A summary of the pipelines, flowlines and umbilicals is presented in Table 3.1.1 in section 3.1. For brevity it is not repeated here.

## 1.2 Pipelines, Flowlines, and Umbilicals

### 1.2.1 Decommissioning Options

For the purposes of the comparative assessment there is an implicit assumption that options for re-use of the pipelines have been exhausted before facilities and infrastructure move into the decommissioning phase and comparative assessment. Therefore, the re-use option has been excluded from this assessment. The decommissioning options can be limited to the following:

- **Complete removal** – This would involve the complete removal of the complete pipeline(s) (i.e. the surface laid sections and the sections buried under rock) by whatever means most practicable and acceptable from a technical perspective.
- **Leave *in situ*** – This would involve removing the surface laid sections but leaving the sections of pipeline(s) buried under rock *in situ* with the stability and burial status of the remaining pipelines being confirmed via future surveys.

Since most of the infrastructure is surface laid the complete removal option can be considered an incremental increase on the leave *in situ* option and includes those sections of pipeline buried under deposited rock. For this reason and to provide context the surface laid sections are included in this assessment although the surface laid sections would be removed in accordance with mandatory requirements.

### 1.2.2 Method

The assessment considered five criteria for both the short-term decommissioning activities and the longer-term for 'legacy' related activities. The criteria were: technical feasibility with three sub-criteria, safety related risks with three sub-criteria, environmental with five sub-criteria, societal effects with three sub-criteria and cost.

### 1.2.3 Conclusion

For the purposes of this comparative assessment, it is assumed that the following pipelines will be fully removed as per mandatory requirements for surface laid infrastructure: PL3094, PL3578, PL3579, PLU3584, PLU3585JW2, PLU3586JW1, PLU4204, PLU4205, PLU4206, PLU4207, PLU4208, PLU4209, PL4973, PL4974, PL4975, PLU4976, and PL4977.

To varying extents the following pipelines are buried under rock (burial length quoted in brackets). PL3095 (204m), PL3580, PL3583, PLU3585 (300m, shared), PL3581, PL3582, PLU3586 (360m, shared), PL4971 (916m), and PLU4972 (1,196m). This comparative assessment addresses those sections of the pipelines that are buried under deposited rock but takes account of the methods used to remove the surface laid sections. This is because in many instances the pipeline might be completely removed more efficiently than the surface laid ends or the removal operations for the complete pipeline may be an extension of the removal of the surface laid ends.

The assessment found that it would be technically feasible to remove all the pipeline infrastructure. PL3095, which is concrete coated would be removed using the 'cut and lift'; method while the flexible flowlines and umbilicals could be completely removed using the reverse reel method. To achieve this, beforehand all the overlying protection and stabilisation features such as concrete mattresses would need to be removed and any overlying rock dispersed to allow the removal operations to proceed unhindered. All the activities are technically and technologically achievable with little chance of project failure. The leave *in situ* option for the pipeline sections buried under rock is also achievable but all the pipeline ends would need to be removed using the 'cut and lift' method.

The safety assessment concluded that on balance overall it would be safer to completely remove the infrastructure than to leave any part in place but the difference between the two decommissioning options is not significant. This is because although PL3095 would be removed using the 'cut and lift' method, the flowlines and umbilicals could be removed using reverse reel, which would involve less material handling offshore and onshore. The leave *in situ* option would mean that although some pipelines would be left buried under rock, although the pipeline ends would all need to be removed using the 'cut and lift' method. It is arguable reverse reel would be safer to achieve than 'cut and lift'.

The environmental assessment found that the use of energy and emissions to air offshore would be less for the complete removal option. This is because the reverse reel method would take less time to execute than the 'cut and lift' method for the surface laid pipelines in the leave *in situ* option. The complete removal option would result in more materials being brought to shore and needing more energy to process, but more material would be recycled as raw material or recovered energy. It is unlikely any of the material recovered could be reused.

The complete removal option would require rock to be dispersed, and the original rock is not native to the seabed. Although it would result in patchy smothering of the seabed, over time it would be colonised by the local flora and fauna.

For all pipelines, the leave *in situ* options would result in materials buried under rock being left to degrade naturally. PL3095 is predominantly manufactured from steel and concrete. Degradation of such materials would not be detrimental to the local environment as the deposition of degraded concrete and steel materials would likely occur very gradually over tens if not hundreds of years [3]. The flowlines and umbilicals have a higher content of composite materials (~15% to 20%) and so the sections buried under rock would take much longer than steel to decompose. As the process would be very slow, occurring gradually over hundreds of years, the products of degradation would be at little detriment to the local marine environment.

Commercial fishing activities in the area use demersal, pelagic and shellfish trawling methods, and fishing effort seems to have been declining in importance since 2019. The dispersal of rock or any rock left *in situ* undisturbed would have a negligible effect on demersal and shellfish effort, and no effect on pelagic trawling in the area.

Either of the pipeline decommissioning options in the Solan area could result in short-term creation of new jobs. Therefore, the significance of the positive impact can be assessed as low.

For material that is brought to shore, the port and the disposal site would likely be existing sites which are used for oil and gas activities and would hold the required permits for waste management. The effect on communities is not considered a significant differentiator between options.

As PL3095 would be removed using the 'cut and lift' method, if would cost less to leave the section buried under rock *in situ*. However, the increase in decommissioning effort to recover the section buried under rock (204m) would be small.

Except for PL4971 and PLU4972, for all the other flowlines and umbilicals the complete removal option would cost less than the leave *in situ* option, even accounting for the rock dispersal operations. This is because once the protection and stabilisation features have been removed and the overlying rock dispersed, the pipelines could be recovered using reverse reel which is a more efficient method than 'cut and lift'. The complete removal of PL4971 and PLU4972 would cost slightly more than leave *in situ* because there would be a relatively short length of product and few mattresses to be recovered at the ends.

In all instances, the cost of the most expensive option is much less than 2x the cost of the cheapest option.

#### **1.2.4 Recommendations**

It is recommended that the Solan pipeline infrastructure be completely removed along with the associated protection and stabilisation features, except rock. As some of the infrastructure is buried under deposited rock, this will need to be dispersed to expose the underlying product. After dispersal, the deposited rock will be left *in situ*.

The following recommendations arise because of this comparative assessment:

- Completely remove the following surface laid pipelines as per mandatory requirements: PL3094, PL3578, PL3579, PLU3584, PLU3585JW2, PLU3586JW1, PLU4204, PLU4205, PLU4206, PLU4207, PLU4208, PLU4209, PL4973, PL4974, PL4975, PLU4976, and PL4977.
- Completely remove the following pipelines PL3095, PL3580, PL3583, PLU3585, PL3581, PL3582, PLU3586, PL4971 and PLU4972.

## **2 INTRODUCTION**

### **2.1 Overview**

The Solan field is in the Northern North Sea in United Kingdom Continental Shelf block 205/26a, to the north of Scotland approximately 134km north-north-west of Kirkwall in the Orkney Islands and ~158.8km west of Lerwick in the Shetland Islands. The water depth at the Solan platform is ~136m LAT and first production occurred in 2016.

The Solan facilities comprise a surface installation, a subsea oil storage tank (SOST), and an oil offloading system. Crude oil is stored in the SOST before periodically being offloaded to a tanker via a Single Anchor Loading (SAL) arrangement. The Solan development has been producing hydrocarbons since 2016 and was developed in two phases with the Drill Centres DC1 and DC2 being completed in 2013, followed by well P3 in 2020. The three production wells P1, P2 and P3 are supported by water injection wells W2 and W1.

Production wells P1 and P2 each export directly to the Solan platform using 268mm diameter flexible flowlines PL3580 and PL3581 respectively. The Solan platform provides seawater for water injection to well W1 and W2 using 268mm diameter flexible flowlines PL3582 and PL3583. Solan provides electrical power, chemicals, and hydraulic fluids to well P1 and well P2 using 176mm diameter umbilicals PLU3585 and PL3586 respectively, and from the Subsea Umbilical Termination Unit (SUTU) and controls to W2 (nearest well P1) and W1 (nearest well P2) using jumpers PLU3585JW2 and PLU3586JW1. Over time the electrical components of both PL3586 and PL3586JW1 were found to be damaged and so they were partly disconnected and replaced by PLU4204 and PLU4205, PLU4206, PLU4207, PLU4208 and PLU4209.

Using 244mm diameter flexible flowline PL4971 production from well P3 is sent to well P1 and onwards to the Solan platform. The controls for the well P1 wing valve and the electrical submersible pump serving well P3 are interlocked so that production from P1 and P3 to Solan cannot occur simultaneously. The Solan platform provides electrical power, chemicals, and hydraulic fluids to well P3 using PLU4972 (205mm) routed to the local SUTU. From there, these are distributed to the various connection points at the well using umbilical jumpers and fly leads (PL4973 (25mm), PL4974 (25mm), PL4975 (56mm), PLU4976 (157mm) and PL4977 (25mm)).

The produced crude oil is exported from the Solan platform to the Subsea Oil Storage Tank (SOST) using PL3578 which is a 368mm flexible flowline. As oil accumulates in the SOST, the ballast water is displaced back to the platform using PL3579 (390mm flexible flowline). Periodically, crude oil is exported from the SOST to an oil tanker via the SAL using the displacement method. This involves pumping seawater from the Solan platform using PL3094 (24in concrete coated pipeline) into the SOST, forcing the oil out of the storage tank towards the tanker using PL3095. PL3095 comprises three parts: a 24in concrete coated pipeline between the SOST and the SAL and 20in lower and upper hoses between the SAL and the tanker connection. Solan provides electrical power, chemicals, and hydraulic fluids to the control valves at the SOST using 148mm diameter umbilical PLU3584.

## 2.2 Solon Area layout

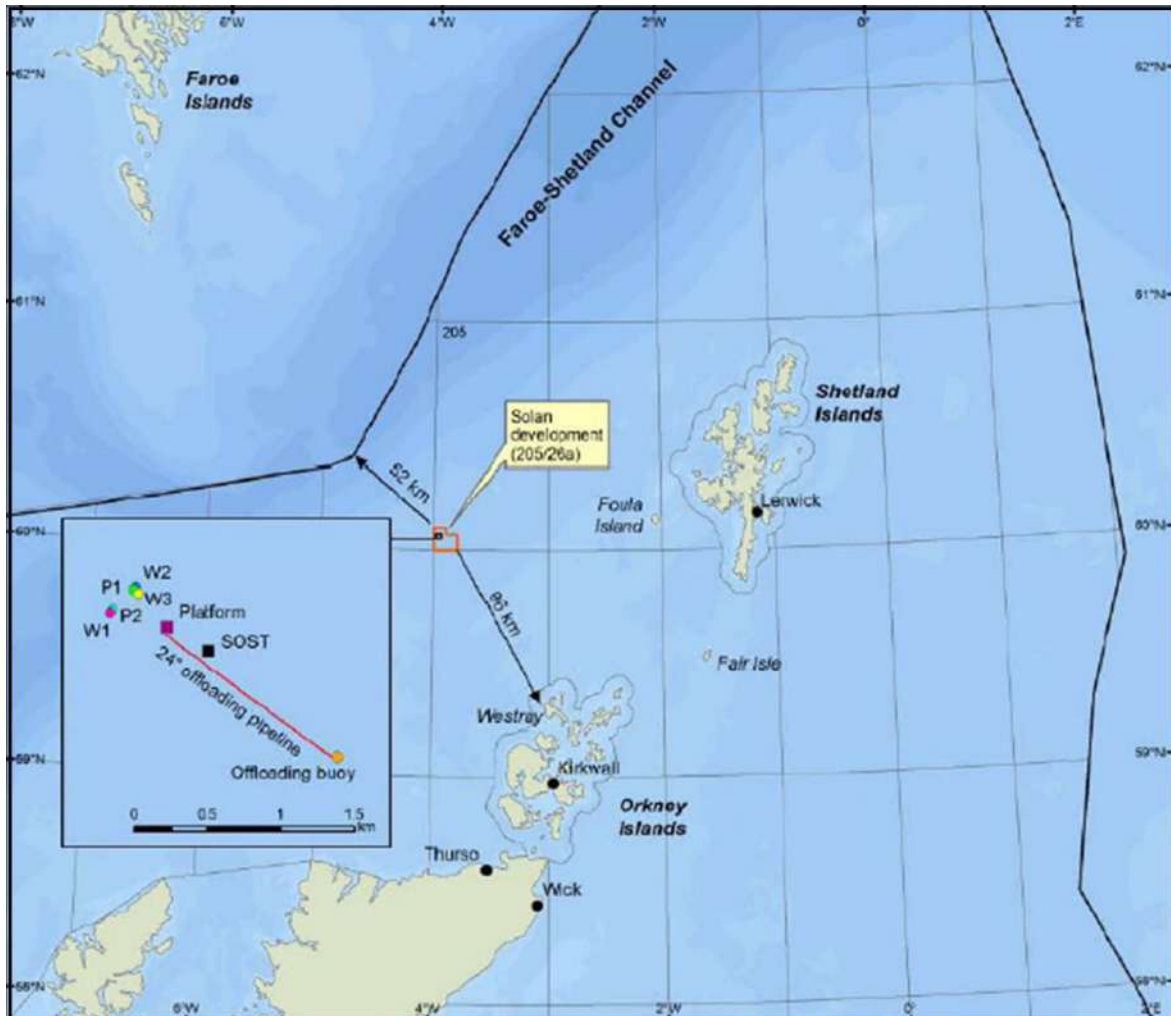


Figure 2.2.1: Overview of Solon location

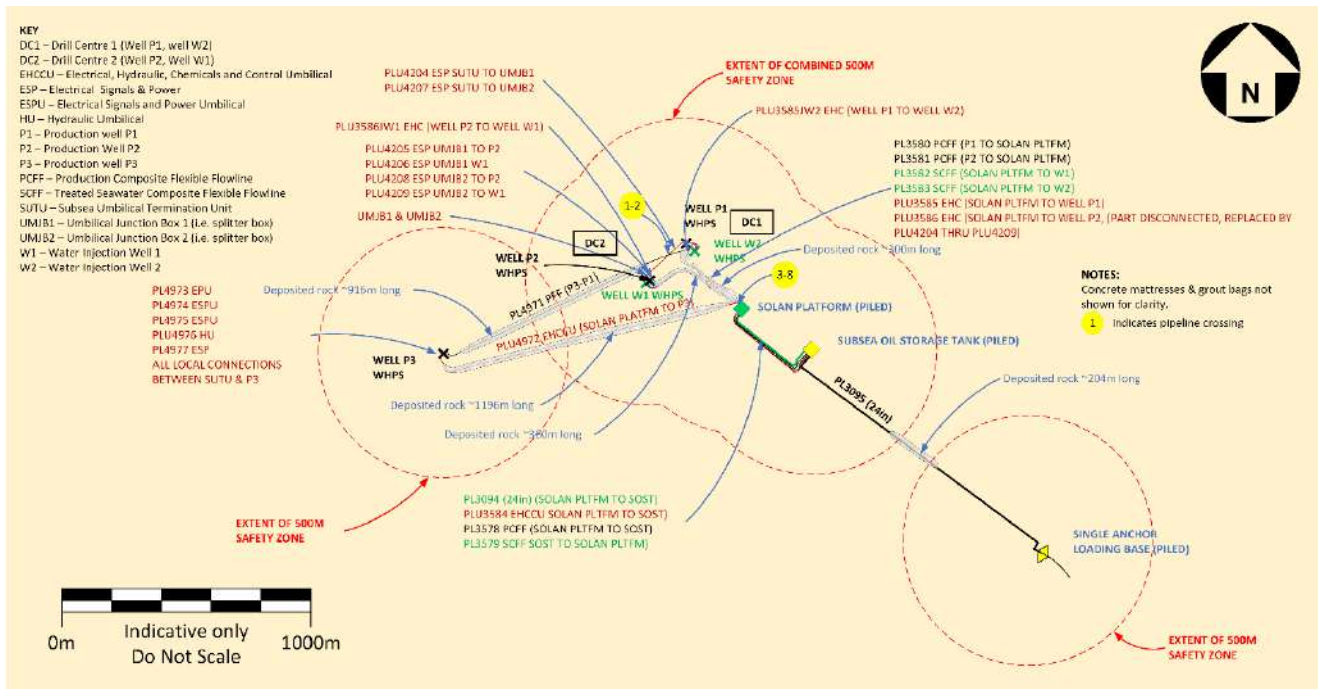


Figure 2.2.2: Overview of Solan infrastructure

### 2.3 Purpose

The purpose of this document is to present a comparative assessment in support of the Solan Decommissioning Programmes [6] as per the OPRED guidance notes [5]. The comparative assessment describes the options considered for decommissioning the pipelines, concrete mattresses, grout bags and deposited rock. The findings have been determined using a qualitative approach as adopted for other comparative assessments prepared in support of several decommissioning programmes for pipelines in the UKCS.

### 2.4 Environmental setting

#### 2.4.1 Overview

The water depth at the Solan platform is ~136m relative to LAT, although the water depth in the area varies from 125.5m in the south to 162.2m in the north-west. The seabed comprises a raised bank of sand or rocks towards the south. Across much of the centre and north of the Solan area and parts of the south, low relief, north-east to south-west striations can be observed. These correlate with areas of gravel, cobbles, and boulders. The maximum gradient within the area is 1.9°.

In the centre, north and parts of the south, seabed sediments comprise gravelly shelly sand with north-east to south-west orientated bands of gravel, cobbles, and boulders predominantly <0.5m high. Across the remainder of the area, in the far north, and parts of the south seabed sediments consist of gravelly shelly sand. In the east of the area, sands formed occasional bands of megaripples less than 0.5 high with a wavelength between 10m and 15m trending east south-east to north-northwest. Under the 0.5m thick layer of Holocene sediment<sup>1</sup> is over consolidated firm to hard glacial till of the Otter Bank Sequence<sup>2</sup>.

<sup>1</sup> The sediments of the Holocene, both continental and marine, cover the largest area of the globe of any epoch in the geologic record, but the Holocene is unique because it is coincident with the late and post-Stone Age history of humankind.  
<sup>2</sup> The Otter Bank Sequence is a Pleistocene near-sea-bed deposit, and it blankets most of the area surrounding Rona and to the north [1].

Occasional larger boulders have been found, the closest of which has a height of 0.5m and lies approximately 551m to the north.

More information may be found in the Environmental Appraisal [7].

### 2.4.2 Protected Areas

The Solan installations and infrastructure are not located inside any (Scottish) Marine Protected Areas (SMPAs), but as indicated in Figure 2.4.1 there are several in the wider area. The “Seas off Foula” is a designated Special Protection Area (SPA) with marine components. The nearest MPAs are situated towards the north-north-west (Faroe Shetland Sponge Belt) and to the south (West Shetland Shelf), some 20km or so from Solan.

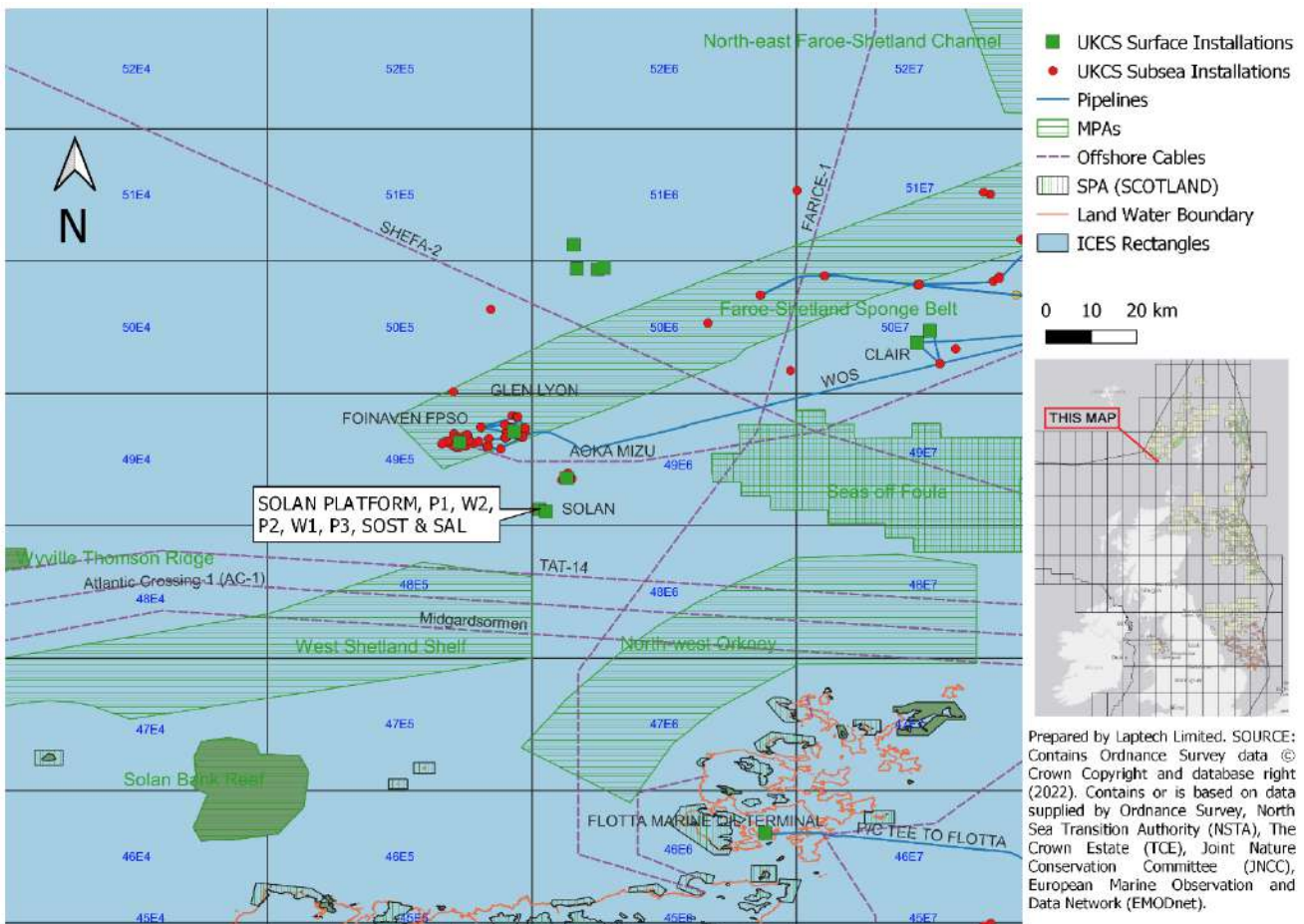


Figure 2.4.1: Locality of the Solan installations and infrastructure in relation to MPAs



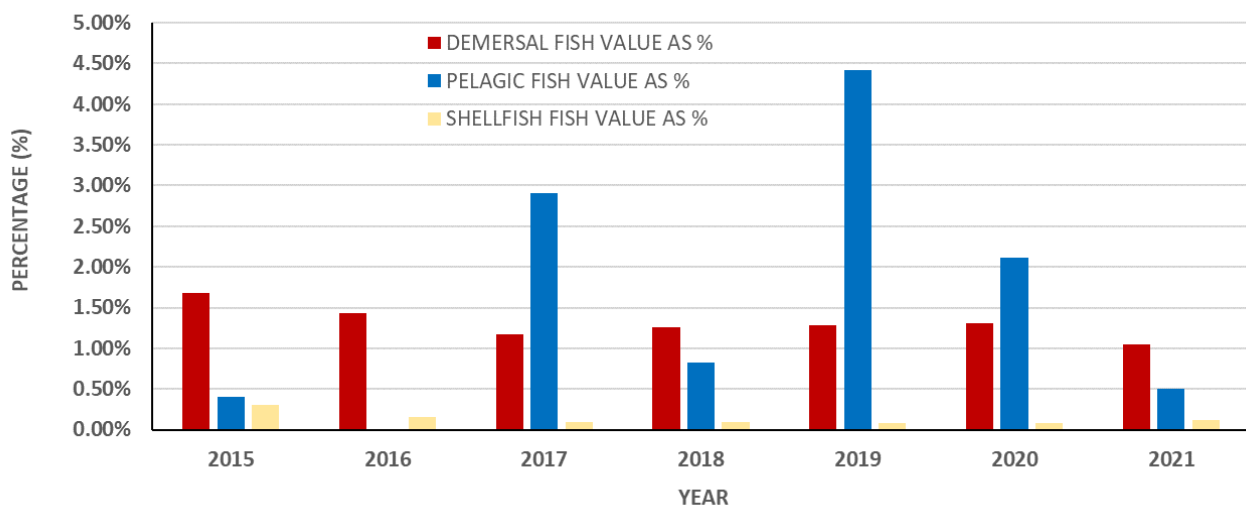
| Scottish Marine Protected Areas / Special Protection Areas |  |                         |             |
|--|--|-------------------------|-------------|
| Name   | Habitats & Species   | Area (km <sup>2</sup> ) | Designation |
| Faroe Shetland Sponge Belt                                 | <b>Species:</b> Ocean quahog<br><b>Habitats:</b><br>Continental slope<br>Deep sea sponge aggregations<br>Offshore subtidal sands and gravels | 5,278                   | SMPA        |
| North-west Orkney  | <b>Species:</b> Sandeels   | 4,356                   | SMPA        |
| Seas off Foula   | <b>Protected Species:</b> A wide variety of seabirds   | 3,412                   | SPA         |
| West Shetland Shelf  | <b>Habitats:</b><br>Offshore subtidal sands and gravels  | 4,083                   | SMPA        |

**Table 2.4.1: Scottish Marine Protected Areas / Special Protection Areas**

### 2.4.3 Commercial Activities - Fishing

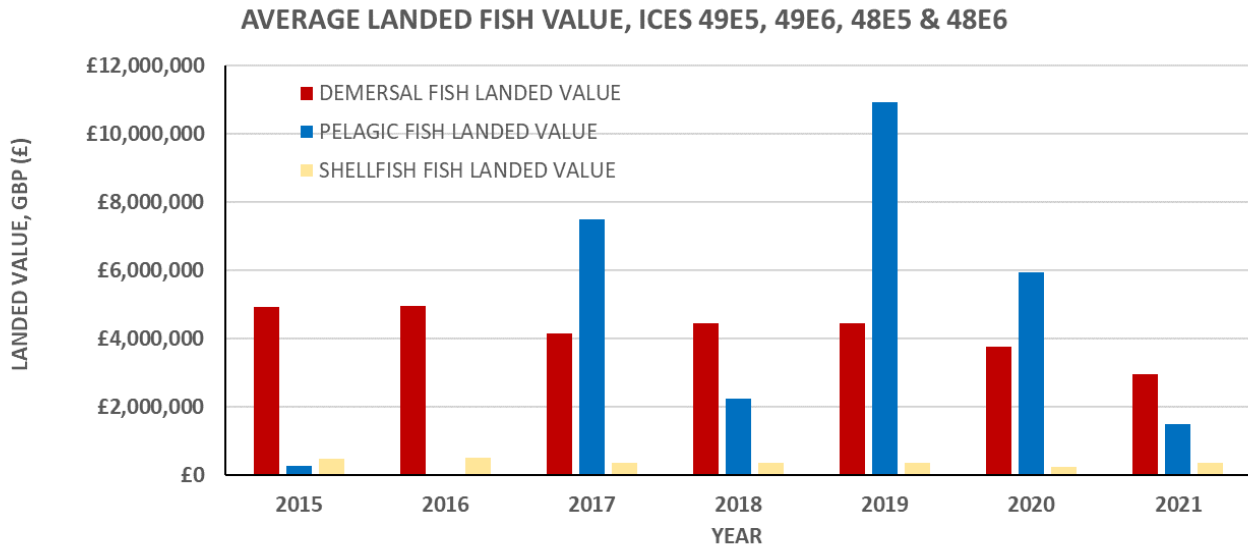
The Solan field is in ICES rectangle 49E6 (Figure 2.4.1) but also close to ICES rectangles 49E5, 48E5 and 48E6. An analysis of the fishing activity between 2015 and 2020 would suggest that as an average the combined area has contributed between 5 and almost 6 percentage points to the overall UK fishing effort in any one year [4]. This is indicated in Figure 2.4.2 and can be considered a significant contribution.

**AVERAGE LANDED FISH VALUE ICES 49E5, 49E6, 48E5 & 48E6, AS % OF OVERALL UK**

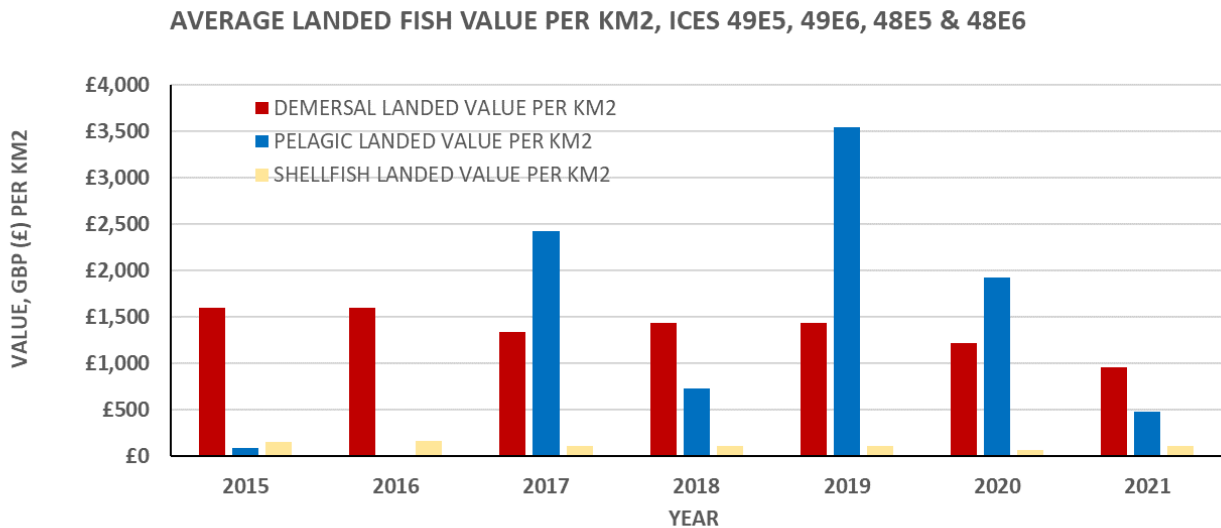


**Figure 2.4.2: Value of fish landings as a percentage of UK fishing effort**

Landed fish value and average landed fish value per km<sup>2</sup> within the four ICES rectangles can be seen in Figure 2.4.3 and Figure 2.4.4 respectively.



**Figure 2.4.3: Landed fish value for ICES 49E5, 49E6, 48E5 & 48E6**



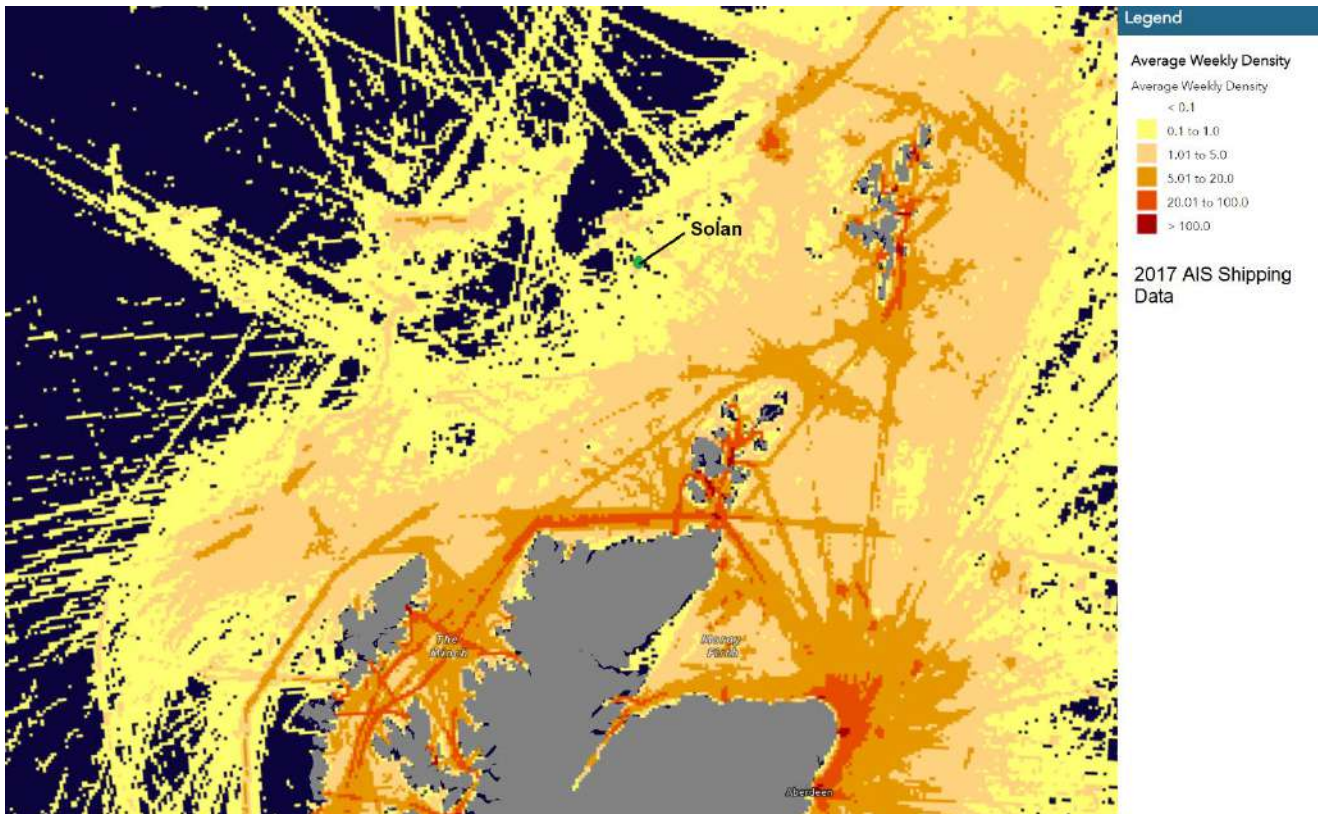
**Figure 2.4.4: Value per km<sup>2</sup> for fish landed from ICES 49E5, 49E6, 48E5 & 48E6**

This indicates that the area is reasonably important to commercial fisheries, and this is consistently reflected in data from the past five years.

In 2021, the average value of demersal, pelagic and shellfish landed per km<sup>2</sup> was £954.24, £482.79, and £114.97 reduced from £1,223.05, £1,929.07, and £70.79 obtained in 2021. These values are calculated by dividing the commercial value of fish landed by the average area of ICES rectangles 49E5, 49E6, 48E5 and 48E6) (3,109km<sup>2</sup>).

#### 2.4.4 Commercial Activity – Vessel Traffic

Although the North Sea has substantial traffic of commercial ships trading between North Sea and Baltic ports, the density of shipping in the North East Atlantic area around Solan area is low, with approximately 0.1 – 1.0 vessels passing each week.



**Figure 2.4.5: Maritime Vessel Weekly AIS Tracking Data, 2017 [1]**

Other activities in the area are limited, with the nearest oil and gas installations being the Glen Lyon FPSO (anchored at the Schiehallion and Loyal oil fields) and Aoka Mizu FPSO installations. The Foinaven FPSO has now departed the area but the subsea infrastructure associated with the various drill centres remains. There is no offshore renewable activity. Refer Figure 2.4.1.

#### **2.4.5 Sandbags**

The number of sandbags noted in the Decommissioning Programmes [6] has generally been established using available data such as as-built drawings and design sketches. However, the number of grout bags around well P3 has been estimated using engineering judgement. The sandbags are documented as containing either sand or grout.

The intention would be to fully remove all sandbags when decommissioning all the surface laid pipelines and umbilicals. In the unlikely event that grout bags are buried and would remain undisturbed during decommissioning operations, they would be left *in situ*. Although several different methods could theoretically be used to remove the grout bags, from a practical perspective it is not known whether the bag material has remained intact since the original installation so there may be other reasons (i.e. damaged or split) why it would be more appropriate to leave the sandbags *in situ*. It is understood that hessian material was used as the container so there should be no issues from an environmental perspective to leaving them *in situ*.

#### **2.4.6 Mattresses**

When a pipeline or structure is installed, it is often provided with protection and stabilisation features, and usually this takes the form of a concrete mattress. Most of the mattresses used at Solon are 6m x 3m x 0.15m, although some of the mattresses on PL3094 and PL3095 are 6m x 4m x 0.3m. Concrete mattresses were used to protect and stabilise the pipelines. It is intended that all concrete mattresses will be removed. No fronded mattresses were used.

### 2.4.7 Deposited Rock

An examination of the Solan related documentation suggests that deposited rock was primarily used to substitute for burial of a pipeline inside a trench. The rock size is graded between 1in and 5in. The deposited rock is summarised as follows:

| Deposited rock summary                                       |                            |              |               |
|--|----------------------------|--------------|---------------|
| Location / Pipeline ID                                       | Depth of Cover (m)         | Length (m)   | Quantity (Te) |
| Between Solan SOST & SAL on PL3095                           | ~2.3                       | 204          | 14,383        |
| Between Solan and Well P1 & W2 on PL3580, PL3583 & PLU3585.  | ~0.5                       | 300          | 4,474         |
| Between Solan and Well P2 & W1 on PL3581, PL3582, & PLU3586. | ~0.5                       | 360          | 5,117         |
| Between Well P2 and Well P1 on PL4971.                       | varies between 0.3 and 1.8 | 916          | 12,562        |
| Between Solan and Well P3 on PLU4972.                        | ~0.3                       | 1,196        | 6,935         |
|  | <b>Sub-total</b>           | <b>2,976</b> | <b>43,225</b> |

**Table 2.4.2: Solan deposited rock summary**

Material left in place would preserve the marine habitat that will have established over the time it has been on the seabed, and in this case its presence will not have a negative impact on the environment, nor impact on the safety of other users of the sea. To remove the pipelines and umbilicals buried underneath, the rock would need to be dispersed over a wider area and left *in situ* or removed to shore.

Technically, there are several methods that could be used to remove *sediment* and loose rock including mechanical dredgers and hydraulic suction dredgers. Examples of mechanical dredgers are a bucket ladder dredger, dipper dredgers, grab or clamshell dredgers, or hydraulic cranes with a backhoe and shovel. Examples of hydraulic suction dredgers include a plain suction dredger, trailing suction hopper dredger, cutter suction dredger, deep suction dredger and a dustpan dredger. A variety of specialist companies are now able to deploy subsea excavation devices such as mass flow excavators (MFEs). MFEs can be very powerful and given sufficient access would have the capability of displacing sediment but not effective for recovering materials to surface.

While most of these methods could be used to recover or displace loose rock the water depths and sea states at Solan mean that most of these methods would not be viable. A grab or clamshell dredger could be used but the method is more suited to much shallower waters. It is very weather dependent, and the water depths and location mean that the method would be time consuming to achieve, if not impractical. A hydraulic suction dredger could be used to recover the rock to a vessel and either onwards to shore or to another subsea location but using an MFE would be the most efficient method for dispersing the rock locally.

To summarise, the methods that could be used to excavate the rock include:

- dredging the rock using a grab or clamshell dredger or deep suction dredger and disposing of the material at an approved offshore location.
- dredging the rock using a grab or clamshell dredger or deep suction dredger and transporting the material to shore to be disposed of in an appropriate manner.
- dispersal of the rock onto the surrounding seabed using a mass flow excavator (MFE).

All these proposed methods would impact on the seabed and associated communities, create sediment plumes, and require additional vessel use with the associated environmental impacts, safety risks, potentially impact on other users of the sea and incur costs.

## 2.5 Assumptions, Limitations, and gaps in Knowledge

The most significant assumptions, limitations and knowledge gaps relating to the comparative assessment are listed below. In addition, it should be noted that the presentation of the distinct categories of risk for comparison has required a degree of engineering judgement. This includes the following technical assumptions:

- A purely qualitative approach has been taken. This has necessarily required a degree of judgement, but since most impacts are related to area of seabed impacted, duration of works and vessel time, this is deemed appropriate.
- Theoretically, it would be technically feasible to remove or displace the overlying rock to remove all pipelines irrespective of the method used. The method used would primarily affect comparisons in the cost assessment.
- PL3094 and PL3095. Technically, removal of the concrete weight coated (CWC) pipeline could be achieved using the 'cut and lift' method of removal.
- Where present, the overlying rock could be excavated or displaced to allow access.
- Complete removal of the flexible flowline(s) and umbilical(s) would be achievable using reverse reel assuming that their integrity could be assured, and that the overlying seabed sediment or deposited rock could be displaced to allow the pipeline(s) to be pulled from the seabed.
- The grade of rock is such that should it be dispersed, it should not present a snagging hazard to demersal trawling activities, but this would best be verified by overtrawl.
- Premier Oil is not aware of any fishing gear snagging reports. To the companies' knowledge no exposures have been of such a magnitude or location such that they have warranted being recorded as a snagging hazard via Kingfisher Information Services on FishSAFE ([www.fishsafe.eu](http://www.fishsafe.eu)).

The following legacy assumptions have also been made:

- An environmental survey would be required on completion of decommissioning activities.
- Any pipeline being left *in situ* would be subject to legacy burial surveys, although given the depth of burial it is possible that this requirement could be re-assessed in several instances following the post-decommissioning surveys.
- In the long term, assuming the size and profile is suitable, deposited rock remaining *in situ* would not present snagging hazards.
- The impact of the procurement of any new materials such as fabricated items or mining of new rock is ignored.
- Impact on commercial activities is proportional to the duration of vessel activity.
- Societal benefits and vessel associated environmental impacts and risks are assumed to be proportional to vessel duration.
- Only a high-level comparison of what differentiates the costs is used but this takes account removal of the surface laid ends as well as the associated protection and stabilisation features.
- The procurement and deposition of additional rock on pipeline ends is ignored in the cost assessment.

Please also refer Appendix D.2 for assumptions that are specific to the cost assessment.

### 3 THE PIPELINES, UMBILICALS AND CABLES

#### 3.1 Overview

The Solan pipelines, flowlines and umbilicals and their burial status are summarised in Table 3.1.1 below. Except for a short section 204m long of PL3095, all the pipeline infrastructure lies within the combined 500m safety zones of the Solan installations:

| Solan pipeline, flowline, and umbilical summary      |                         |        |            |
|--|-------------------------|--------|------------|
| Description  | Route                   | Burial | Length (m) |
| PL3094 24in tank displacement pipeline               | Solan to SOST           |        | 546m       |
| PL3095 24/20in oil export pipeline & offloading hose | SOST to tanker via SAL  | 204m   | 1,521m     |
| PL3578 10in oil export flowline                      | Solan to SOST           |        | 602m       |
| PL3579 12in water ballast flowline                   | SOST to Solan           |        | 613m       |
| PL3580 P1 6in prod. flowline                         | Well P1 to Solan        | 300m   | 538m       |
| PL3581 P2 6in prod. flowline                         | Well P2 to Solan        | 360m   | 596m       |
| PL3582 W1 6in WI flowline                            | Solan to well W1        | 360m   | 612m       |
| PL3583 W2 6in WI flowline                            | Solan to well W2        | 300m   | 577m       |
| PLU3584 SOST control umbilical                       | Solan to SOST           |        | 584m       |
| PLU3585 P1 control umbilical                         | Solan to well P1        | 300m   | 538m       |
| PLU3586 P2 control umbilical                         | Solan to well P2        | 360m   | 594m       |
| PLU3585JW2 W2 control umbilical jumper               | Well P1 to well W2      |        | 40m        |
| PLU3586JW1 W1 control umbilical jumper               | Well P2 to well W1      |        | 40m        |
| PLU4204 Replacement electrical umbilical             | SUTU to UMBJB1          |        | 233m       |
| PLU4205 P2 replacement elect. umbilical jumper       | UMBJB1 to well P2       |        | 50m        |
| PLU4206 W1 replacement elect. umbilical jumper       | UMBJB1 to well W1       |        | 50m        |
| PLU4207 replacement elect. umbilical                 | SUTU to UMBJB2          |        | 233m       |
| PLU4208 P2 replacement elect. umbilical jumper       | UMBJB2 to well P2       |        | 50m        |
| PLU4209 W1 replacement elect umbilical jumper        | UMBJB2 to well W1       |        | 50m        |
| PL4971 P3 6in flexible flowline                      | Well P3 to well P1      | 916m   | 1,097m     |
| PLU4972 P3 control umbilical                         | Solan to well P3 SUTU   | 1,196m | 1,463m     |
| PL4973 P3 1in elect. fly lead                        | Well P3 SUTU to well P3 |        | 15m        |
| PL4974 P3 1in elect. & communications fly lead       | Well P3 SUTU to well P3 |        | 20m        |
| PL4975 P3 2in elect. & communications fly lead       | Well P3 SUTU to well P3 |        | 20m        |
| PLU4976 P3 6in hydraulic fluids fly lead             | P3 SUTU to well P3      |        | 16m        |
| PL4977 P3 1in elect. & communications fly lead       | Well P3 SUTU to well P3 |        | 15m        |

#### NOTES

1. PL3095. Excluding the length of the pipespools and the lower and upper parts of the offloading hose the concrete weight coated section of the pipeline is 1,100m long.
2. PL3580, PL3583, PLU3585 are all buried under the same rock for most of their length.
3. PL3581, PL3582, PLU3586 are all buried under the same rock for most of their length.

**Table 3.1.1: Solan pipeline, flowline, and umbilical summary**

#### 3.2 Pipeline Exposure & Spans

Except for the 204m long section of PL3095 buried under rock, all the pipelines are contained within the combined 500m safety zone. As they are all surface laid, no burial profiles have been prepared.

### 3.3 Pipeline Crossings

Some of the pipelines and umbilicals considered in this comparative assessment cross over other pipelines and umbilicals, as indicated in the figures in Figure B.1.1 and Figure B.2.1. For oil and gas related infrastructure, this can usually be determined by the pipeline number. The higher pipeline number will usually cross over the top of a pipeline with a lower identification number, so for example, PL4971 would cross over PL4204 or PLU4207. This is illustrated in Figure 3.3.1. The pipeline crossings are summarised in section 3.4. No third-party pipelines pass under or over the Solan infrastructure.

Over/Under convention:

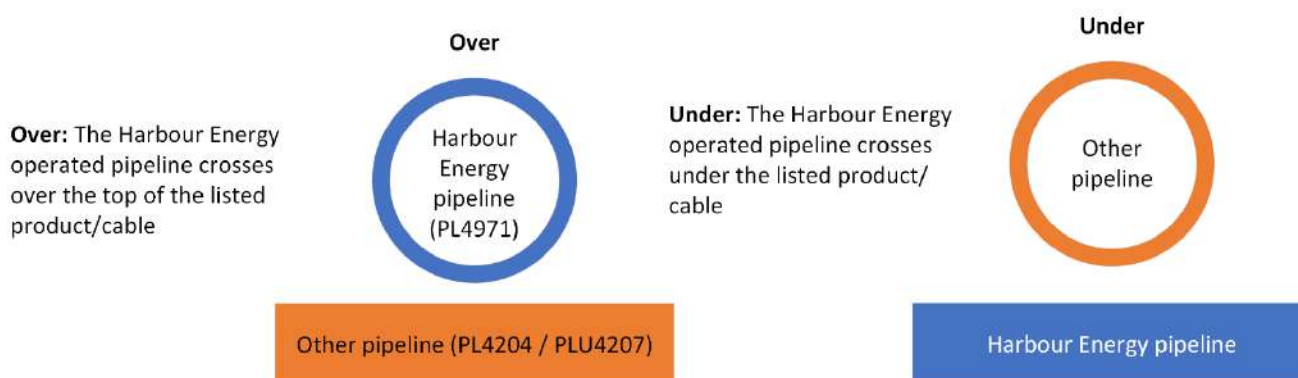


Figure 3.3.1: Over/under convention for pipeline crossings

### 3.4 Pipeline Crossing Summary

The pipeline crossings are summarised in Table 3.4.1 below.

| Solan pipeline crossing information              |  |  |  |
|--|--|--|--|
| ID   | Pipeline description   | Location                               | Protection / comment   |
| <b>SOLAN, P1/W2 &amp; P2/W1 500M SAFETY ZONE</b> |  |  |  |
| 1-2  | PL4971 over PLU4204 & PLU4207                                  | Inside Solan combined 500m safety zone | Concrete mattresses, grout bags. Refer Figure B.1.1, schematic ID 1-2. |
| 3-8  | PLU4972 over PL3580, PL3581, PL3582, PL3583, PLU3585 & PLU3586 | Inside Solan combined 500m safety zone | Concrete mattresses, grout bags. Refer Figure B.1.1, schematic ID 3-8. |

Table 3.4.1 Solan pipeline, flowline, and umbilical crossings

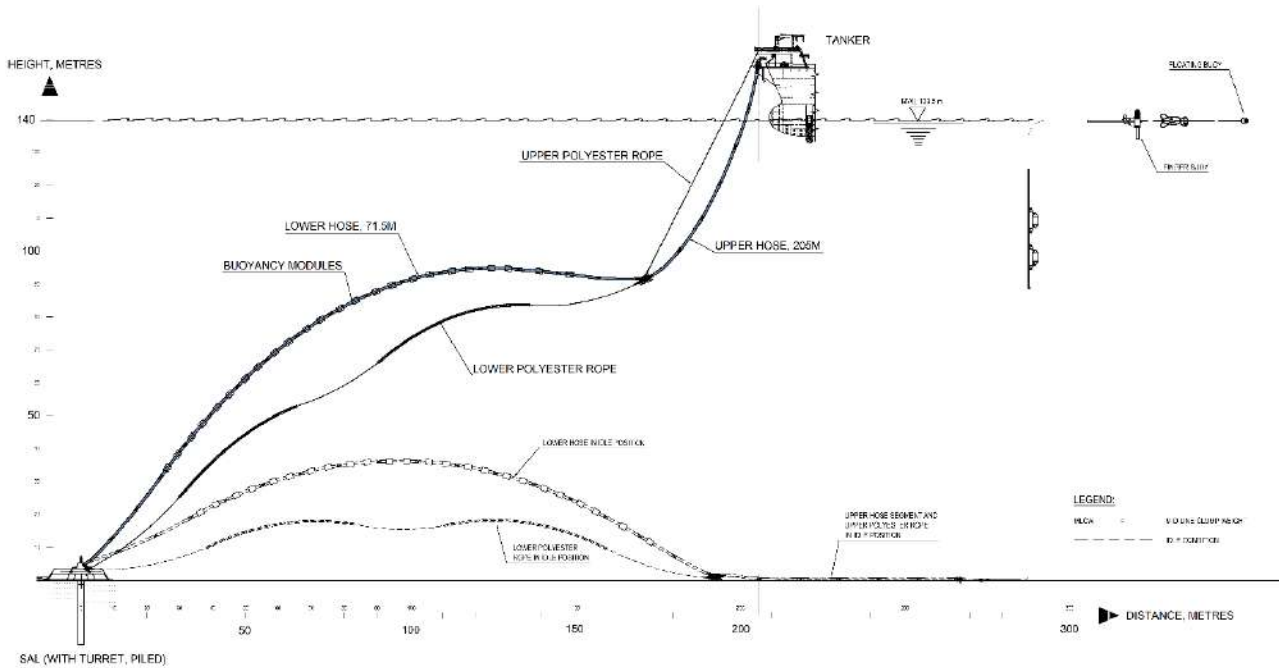
### 3.5 The SOST Pipelines, Flowlines and Umbilicals

#### 3.5.1 PL3094 24in Tank Displacement Pipeline, Solan Platform to SOST

PL3094 is a 24in carbon steel pipeline that is 546m long and routed between the Solan platform and the SOST. The 116m riser is coated in neoprene and the pipeline is coated in 3-layer polypropylene (3LPP) overlain with a 40mm thick concrete weight coating (CWC, 263m long) throughout most of the length except for the riser section and tie-in spools at each end. The pipeline was installed using the S-lay method and is laid on the seabed. On the approaches at each end it is protected from dropped objects and stabilised with concrete mattresses. As it is surface laid, a burial profile is not included. The route of the pipeline along with the associated protection and stability features are shown in Figure B.1.1 and Figure B.3.1.

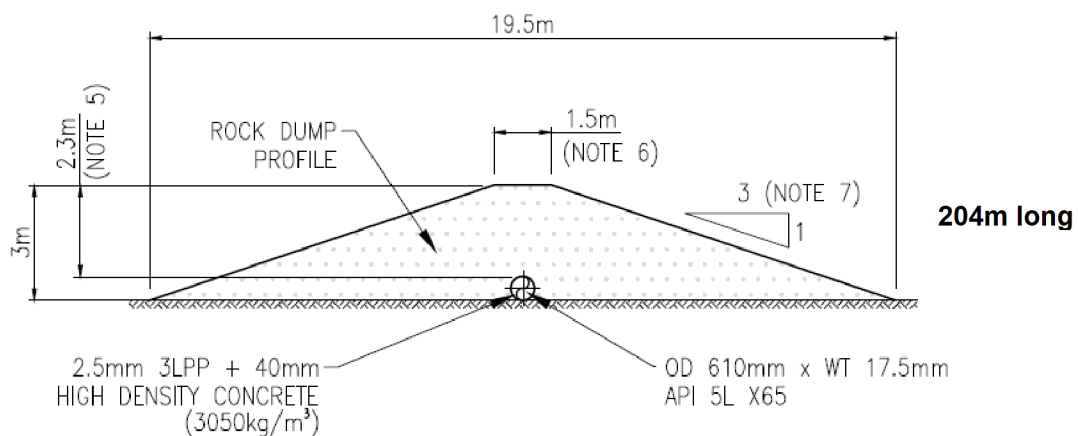
### 3.5.2 PL3095 24/20in Oil Export Pipeline & Offloading Hose, SOST to Offloading Connection

PL3095 is a pipeline that is 1,521m long. It comprises two-main parts: the first part is the 24in steel pipeline between the SOST and the Single Anchor Loading (SAL) turret, and the second part comprises the lower and upper parts of a 20in 'offloading' hose between the SAL and the tanker offloading connection. The main pipeline (i.e. excluding the tie-spools at each end) is 1,100m long, with a 3LPP coating overlain with a 40mm thick CWC. The lower and upper sections of the offloading hose are 71.5m and 205m long respectively and are accompanied with polyester rope and buoyancy aids to facilitate handling (Figure 3.5.1).



**Figure 3.5.1: PL3095 lower and upper hose sections at SAL**

The rigid section of the pipeline was installed using the S-lay method and is laid on the seabed. On the approaches at each end it is protected from dropped objects and stabilised with concrete mattresses. As it is surface laid, a burial profile is not included although there is a 204m long section of the pipeline between the SOST and SAL 500m safety zones that is buried under deposited rock (Figure 3.5.2 and Figure B.1.1).



Total estimated rock quantity: **14,383 Te**

**Figure 3.5.2: PL3095 profile of deposited rock, 204m long x 20m wide**



### **3.5.3 PL3578 10in Oil Export Flowline, Solan Platform to SOST**

PL3578 is a 368mm diameter composite flexible flowline that is 602m long, routed between the Solan platform and the SOST. Figure A.1.1 presents a schematic of the typical construction of a composite flexible flowline. The first part is the flexible riser 171m long. The main part of the flowline is 421m long and the rest of the length is constructed using rigid tie-in spools at each end. At intervals along the flowline and on the approaches at each end it is protected from dropped objects and stabilised with concrete mattresses. As it is surface laid, a burial profile is not included. The route of the flowline along with the associated protection and stability features are shown in Figure B.1.1 and Figure B.3.1.

### **3.5.4 PL3579 12in Water Ballast Flowline, SOST to Solan Platform**

PL3579 is a 390mm diameter composite flexible flowline that is 613m long, routed from SOST to the Solan platform. Figure A.1.1 presents a schematic of the typical construction of a composite flexible flowline. The main flowline is 437m long and the rest of the length is constructed using rigid tie-in spools at each end. At the platform, the flowline splits into two 55m long caissons. At intervals along the flowline and on the approaches at each end it is protected from dropped objects and stabilised with concrete mattresses. As it is surface laid, a burial profile is not included. The route of the pipeline along with the associated pipeline protection and stability features are shown in Figure B.1.1 and Figure B.3.1.

### **3.5.5 PLU3584 SOST Control Umbilical, Solan Platform to SOST**

PLU3584 is a 148mm diameter umbilical that is 584m long, routed from the Solan platform to SOST. Figure A.2.1 presents a schematic of the construction of the umbilical. Part is suspended inside a J-tube connected to the Solan jacket and part is laid on the seabed where it is protected and stabilised by concrete mattresses throughout its length. As it is surface laid, a burial profile is not included. The route of the pipeline along with the associated pipeline protection and stability features are shown in Figure B.1.1 and Figure B.3.1.

## **3.6 The DC1 and DC2 Pipelines, Flowlines and Umbilicals**

### **3.6.1 PL3580 Well P1 6in Production Flowline, Well P1 to Solan Platform**

PL3580 is a 268mm diameter composite flexible flowline that is 538m long, routed between well P1 and the Solan platform. Figure A.1.1 presents a schematic of the typical construction of a composite flexible flowline. The flexible riser at the Solan platform is 160m long. The main part of the flowline is 360m long and the rest of the length is constructed using rigid tie-in spools at each end. For most of its length the flowline is buried under the same deposited rock as PL3583 and PLU3585 (Table 2.4.2). On the approaches at each end it is protected from dropped objects and stabilised with concrete mattresses. Albeit buried under deposited rock, as it is surface laid, a burial profile is not included. The route of the flowline along with the associated protection and stability features are shown in Figure B.1.1 and Figure B.5.1.

### **3.6.2 PL3581 Well P2 6in Production Flowline, Well P2 to Solan Platform**

PL3581 is a 268mm diameter composite flexible flowline that is 596m long, routed between well P2 and the Solan platform. Figure A.1.1 presents a schematic of the typical construction of a composite flexible flowline. The flexible riser at the Solan platform is 166m long. The main part of the flowline is 416m long and the rest of the length is constructed using rigid tie-in spools at each end. For most of its length the flowline is buried under the same deposited rock as PL3582 and PLU3586 (Table 2.4.2). On the approaches at each end it is protected from dropped objects and stabilised with concrete mattresses. Albeit buried under deposited rock, as it is surface laid, a burial profile is not included. The route of the flowline along with the associated protection and stability features are shown in Figure B.1.1 and Figure B.5.1.

### **3.6.3 PL3582 Well W1 6in Water Injection Flowline, Solan Platform to Well W1**

PL3582 is a 268mm diameter composite flexible flowline that is 612m long, routed between the Solan platform and well W1. Figure A.1.1 presents a schematic of the typical construction of a composite flexible flowline. The

flexible riser at the Solon platform is 164m long. The main part of the flowline is 435m long and the rest of the length is constructed using rigid tie-in spools at each end. For most of its length the flowline is buried under the same deposited rock as PL3581 and PLU3586 (Table 2.4.2). On the approaches at each end it is protected from dropped objects and stabilised with concrete mattresses. Albeit buried under deposited rock, as it is surface laid, a burial profile is not included. The route of the flowline along with the associated protection and stability features are shown in Figure B.1.1 and Figure B.5.1.

#### **3.6.4 PL3583 Well W2 6in Water Injection Flowline, Solon platform to Well W2**

PL3583 is a 268mm diameter composite flexible flowline that is 577m long, routed between the Solon platform and well W2. Figure A.1.1 presents a schematic of the typical construction of a composite flexible flowline. The flexible riser at the Solon platform is 160m long. The main part of the flowline is 360m long and the rest of the length is constructed using rigid tie-in spools at each end. For most of its length the flowline is buried under the same deposited rock as PL3580 and PLU3585 (Table 2.4.2). On the approaches at each end it is protected from dropped objects and stabilised with concrete mattresses. Albeit buried under deposited rock, as it is surface laid, a burial profile is not included. The route of the flowline along with the associated protection and stability features are shown in Figure B.1.1 and Figure B.5.1.

#### **3.6.5 PLU3585 Well P1 Control Umbilical, Solon Platform to Well P1**

PLU3585 is a 176mm diameter umbilical and it is 538m long, routed from the Solon platform to well P1. Figure A.3.1 presents a schematic of the construction of the umbilical. The first part of the umbilical is suspended inside a J-tube connected to the Solon jacket. For most of its length the umbilical is buried under the same deposited rock as PL3580 and PL3583 (Table 2.4.2). On the approaches at each end it is protected from dropped objects and stabilised with concrete mattresses. Albeit buried under deposited rock, as it is surface laid, a burial profile is not included. The route of the flowline along with the associated protection and stability features are shown in Figure B.1.1 and Figure B.5.1.

#### **3.6.6 PLU3586 Well P2 Control Umbilical, Solon Platform to Well P2**

PLU3586 is a 176mm diameter umbilical and it is 594m long, routed from the Solon platform to well P2. Figure A.3.1 presents a schematic of the construction of the umbilical. The first part of the umbilical is suspended inside a J-tube connected to the Solon jacket. For most of its length the umbilical is buried under the same deposited rock as PL3581 and PL3582 (Table 2.4.2). On the approaches at each end it is protected from dropped objects and stabilised with concrete mattresses. Albeit buried under deposited rock, as it is surface laid, a burial profile is not included. The route of the flowline along with the associated protection and stability features are shown in Figure B.1.1 and Figure B.5.1. A few years ago, the umbilical suffered a failure of some of the electrical cores, and so it was partially disconnected with the associated functionality being replaced by PLU4204 through PL4209 routed from the SUTU next to well P1 to well P2 and W1 via two umbilical junction boxes Junction Box 1 and Junction Box 2.

#### **3.6.7 PLU3585JW2 Well W2 Control Umbilical Jumper, Well P1 to Well W2**

PLU3585JW2 is a tied hose bundle 40m long, routed from well P1 to well W2. The hose bundle is protected from dropped objects and stabilised with concrete mattresses. The route of the hose bundle along with the associated protection and stability features are shown in Figure B.1.1 and Figure B.5.1.

#### **3.6.8 PLU3586JW1 Well W1 Control Umbilical Jumper, Well P2 to Well W1**

PLU3586JW1 is a tied hose bundle 40m long, routed from well P2 to well W1. The hose bundle is protected from dropped objects and stabilised with concrete mattresses. The route of the hose bundle along with the associated protection and stability features are shown in Figure B.1.1 and Figure B.5.1.

### **3.6.9 PLU4204 Replacement Electrical Umbilical, SUTU to Umbilical Junction Box 1**

PLU4204 is an electrical umbilical routed from the Subsea Umbilical Termination Unit (SUTU) next to well P1 to umbilical junction box 1 (UMBJB1) where the signals are split into PLU4205 (onto well P2) and PLU4206 (onto well W1). It is 233m long. The umbilical is protected and stabilised with concrete mattresses. The route of the umbilical along with the associated protection and stability features are shown in Figure B.1.1 and Figure B.5.1.

### **3.6.10 PLU4205 Well P2 Replacement Electrical Umbilical Jumper, Umbilical Junction Box 1 to Well P2**

PLU4205 is an electrical umbilical routed from umbilical junction box 1 to well P2. It is 50m long. The umbilical is protected and stabilised with concrete mattresses. The route of the umbilical along with the associated protection and stability features are shown in Figure B.1.1 and Figure B.5.1.

### **3.6.11 PLU4206 Well W1 Replacement Electrical Umbilical Jumper, Umbilical Junction Box 1 to Well W1**

PLU4206 is an electrical umbilical routed from umbilical junction box 1 to well W1. It is 50m long. The umbilical is protected and stabilised with concrete mattresses. The route of the umbilical along with the associated protection and stability features are shown in Figure B.1.1 and Figure B.5.1.

### **3.6.12 PLU4207 Replacement Electrical Umbilical, SUTU to Umbilical Junction Box 2**

PLU4207 is an electrical umbilical routed from the SUTU next to well P1 to umbilical junction box 2 (UMBJB2) where the electrical signals and power are split into PLU4208 (onto well P2) and PLU4209 (onto well W1). It is 233m long. The umbilical is protected and stabilised with concrete mattresses. The route of the umbilical along with the associated protection and stability features are shown in Figure B.1.1 and Figure B.5.1.

### **3.6.13 PLU4208 Well P2 Replacement Electrical Umbilical Jumper, Umbilical Junction Box 2 to Well P2**

PLU4208 is an electrical umbilical routed from umbilical junction box 2 to well P2. It is 50m long. The umbilical is protected and stabilised with concrete mattresses. The route of the umbilical along with the associated protection and stability features are shown in Figure B.1.1 and Figure B.5.1.

### **3.6.14 PLU4209 Well W1 Replacement Electrical Umbilical Jumper, Umbilical Junction Box 2 to Well W1**

PLU4209 is an electrical umbilical routed from umbilical junction box 2 to well W1. It is 50m long. The umbilical is protected and stabilised with concrete mattresses. The route of the umbilical along with the associated protection and stability features are shown in Figure B.1.1 and Figure B.5.1.

## **3.7 The Well P3 Flowlines and umbilicals**

### **3.7.1 PL4971 Well P3 6in Flexible Flowline, Well P3 to Well P1**

PL4971 is a 244mm diameter composite flexible flowline that is 1,097m long, routed between well P3 and well P1. Figure A.1.1 presents a schematic of the typical construction of a composite flexible flowline. The controls for the well P1 wing valve and the electrical submersible pump serving well P3 are interlocked so that production from P1 and P3 to Solan cannot occur simultaneously. The flowline is buried under deposited rock for 916m (Table 2.4.2) and on the approaches at each end it is protected from dropped objects and stabilised with concrete mattresses. Albeit buried under deposited rock, as it is surface laid, a burial profile is not included. The route of the flowline along with the associated protection and stability features are shown in Figure B.1.1, Figure B.5.1 (DC1 & DC2) and Figure B.6.1 (well P3).

PLU4972 crosses over PLU4204 & PLU4207 in the combined Solan 500m safety zone (Refer Figure B.1.1, schematic ID 1-2 and Table 3.4.1).

### **3.7.2 PLU4972 Well P3 Control Umbilical, Solan Platform to Well P3 SUTU**

PLU4972 is a 205mm diameter umbilical and it is 1,463m long, routed from the Solan platform to a SUTU at well P3. Figure A.4.1 presents a schematic of the construction of the umbilical. The first part of the umbilical is

suspended inside a J-tube connected to the Solon jacket. The rest of the umbilical is laid on the seabed, either buried under deposited rock (1,196m long) or protected and stabilised with concrete mattresses at each end. Albeit buried under deposited rock, as it is surface laid, a burial profile is not included. The route of the flowline along with the associated protection and stability features are shown in Figure B.1.1, Figure B.2.1 (Solon platform) and Figure B.6.1 (well P3).

PLU4972 crosses over the DC1 and DC2 related infrastructure at the Solon platform (Refer Table 3.4.1, Figure B.1.1 and Figure B.2.1).

### **3.7.3 PL4973 Well P3 1in Electrical Fly Lead, Well P3 SUTU to Well P3**

PL4973 is a short 25mm diameter electrical fly lead that provides electrical power. It is 15m long, routed from the SUTU at well P3 to well P3. The electrical fly lead is laid on the seabed and along with PL4974, PL4975, PLU4976 and PL4977 it is protected and stabilised with concrete mattresses. The location and associated protection and stability features are shown in Figure B.1.1, and Figure B.6.1.

### **3.7.4 PL4974 Well P3 1in Electrical & Communications Fly Lead, Well P3 SUTU to Well P3**

PL4974 is a short 25mm diameter electrical and communications fly lead that provides electrical signals and power. It is 20m long, routed from the SUTU at well P3 to well P3. It is laid on the seabed and along with PL4973, PL4975, PLU4976 and PL4977 it is protected and stabilised with concrete mattresses. The location and associated protection and stability features are shown in Figure B.1.1, and Figure B.6.1.

### **3.7.5 PL4975 Well P3 2in Electrical & Communications Fly Lead, Well P3 SUTU to Well P3**

PL4975 is a short 56mm diameter electrical and communications fly lead that provides electrical signals and power. It is 20m long, routed from the SUTU at well P3 to well P3. It is laid on the seabed and along with PL4973, PL4974, PLU4976 and PL4977 it is protected and stabilised with concrete mattresses. The location and associated protection and stability features are shown in Figure B.1.1, and Figure B.6.1.

### **3.7.6 PLU4976 Well P3 6in Hydraulic Fluids Fly Lead, Well P3 SUTU to well P3**

PLU4976 is a short 157mm diameter fly lead with hydraulic oil that provides hydraulic oil to well P3. It is 16m long, routed from the SUTU at well P3 to well P3. Figure A.5.1 presents a cross-section schematic of its construction. It is laid on the seabed and along with PL4973, PL4974, PL4975 and PL4977 it is protected and stabilised with concrete mattresses. The location and associated protection and stability features are shown in Figure B.1.1, and Figure B.6.1.

### **3.7.7 PL4977 Well P3 1in Electrical & Communications Fly Lead, Well P3 SUTU to Well P3**

PL4977 is a short 25mm diameter electrical and communications fly lead that provides electrical signals and power. It is 15m long, routed from the SUTU at well P3 to well P3. It is laid on the seabed and along with PL4973, PL4974, PL4975 and PLU4976 it is protected and stabilised with concrete mattresses. The location and associated protection and stability features are shown in Figure B.1.1, and Figure B.6.1.

## 4 DECOMMISSIONING OPTIONS

### 4.1 Pipelines

It is assumed that all surface laid sections of the pipelines together with the associated protection and stabilisation features such as concrete mattresses that are not buried under deposited rock will be fully recovered in accordance with mandatory requirements.

This means that only the sections of the pipelines, flowlines and umbilicals buried under deposited rock are subject to comparative assessment.

The decommissioning options are:

- **Complete removal** – This would involve the complete removal of the complete pipeline(s) (i.e. the surface laid sections and the sections buried under rock) by whatever means most practicable and acceptable from a technical perspective.
- **Leave *in situ*** – This would involve removing the surface laid sections but leaving the sections of pipeline(s) buried under rock *in situ* with the stability and burial status of the remaining pipelines being confirmed via future surveys.

Referring to Table 2.4.2 and Table 3.1.1 presented earlier, these decommissioning options apply to the following pipelines, flowlines, and umbilicals:

- PL3095, the section buried under deposited rock is 204m long.
- PL3580, PL3583, PLU3585, the section(s) buried under deposited rock are 300m long.
- PL3581, PL3582, PLU3586, the section(s) buried under deposited rock are 360m long.
- PL4971, the section buried under deposited rock is 916m long.
- PLU4972, the section buried under deposited rock is 1,196m long.

Therefore, the comparative assessment will be concerned with these pipelines. Since most of the infrastructure is surface laid the complete removal option can be considered an incremental increase on the leave *in situ* option and includes those sections of pipeline buried under deposited rock. For this reason and to provide context the surface laid sections are included in this assessment although the surface laid sections would be removed in accordance with mandatory requirements. Please refer Table 4.1.1 for a more detailed description of the options for each pipeline.

| Decommissioning options and methods (buried sections only)   |   |   |
|--|---|---|
| Pipeline ID & description  | Complete removal  | Leave <i>in situ</i>  |
| PL3095, 24in steel pipeline, CWC   | Disperse overlying rock using MFE.<br>Remove pipeline using the 'cut and lift' method.  | Cut the ends of the pipeline where it enters and exits rock.<br>Bury the cut ends in rock, either by redistribution of existing rock or by adding additional rock or a combination of both.<br>Given the existing depth of cover, assume an additional 75Te of rock would be required to bury each of the cut pipeline ends.                                |
| PL3580, PL3583 6in flexible flowlines<br>PLU3585, 176mm umbilical  | Disperse overlying rock using MFE<br>As a continuation of removing the surface laid ends, remove flexible flowlines using the 'reverse reel' method with the 'cut and lift' method available as backup. | Cut the ends of the flowlines and umbilical where they enter and exit rock.<br>Bury each of the cut ends in rock, either by redistribution of existing rock or by adding additional rock or a combination of both.<br>Given the existing depth of cover, assume an additional 15Te of rock (total) would be required to bury each of the cut pipeline ends. |
| PL3581, PL3582 6in flexible flowlines<br>PLU3586, 176mm umbilical  | Refer activities for PL3580, PL3583 & PLU3585 described above.  | Refer PL3580, PL3583 & PLU3585.   |
| PL4971 244mm flexible flowline   | Refer activities for PL3580, PL3583 & PLU3585 described above.  | Cut the ends of the flowline where it enters and exits rock.<br>Bury each of the cut ends in rock, either by redistribution of existing rock or by adding additional rock or a combination of both activities.<br>Given the existing depth of cover, assume an additional 15Te of rock would be required to bury each of the cut pipeline ends.             |
| PLU4972 205mm umbilical  | Refer activities for PL3580, PL3583 & PLU3585 described above.  | Refer PL4971.   |
| <p><b>NOTE:</b></p> <p>1. The removal of the surface laid sections either side of the sections buried under rock would most likely be achieved using the cut and lift method, because the water depth and lengths of pipelines, flowlines, and umbilicals being recovered would not be conducive to recovery using the 'reverse reel' method. However, once the concrete mattresses have been removed, and the rock removed or dispersed, the 'reverse reel' method would likely be achievable making the recovery process more efficient.</p> |   |   |

**Table 4.1.1: Decommissioning the pipelines, flowlines, and umbilicals**

## **5 COMPARATIVE ASSESSMENT METHODOLOGY**

The comparative assessment is largely qualitative, conducted at a level that is sufficient to differentiate the options. However, in some cases, for example such as cost, it can be necessary to examine the differences in more detail and quantitatively to provide clarity. The comparative assessment considers generic evaluation criteria and specific sub-criteria in line with OPRED guidance notes [4]. These elements are considered for short-term work as the assets are decommissioned, as well as over the longer-term as 'legacy' impacts and risks. The criteria and sub-criteria for the pipelines, flexible flowlines, and umbilicals are presented in Table 4.1.1 below.

No scores have been determined and no weightings are used. However, risk matrices have been used to determine if the planned and unplanned impacts would be, for example, broadly acceptable, possibly acceptable, unlikely to be acceptable or not acceptable.

The coloured cells for each of the technical, safety, environment, socio-economic and cost elements being considered are used in Appendix C. Cells coloured red indicate high risk, high impact, and less desirable outcomes. Green coloured cells indicate less risk, less impact, and more desirable outcomes. Cells coloured orange sit in-between red and green and may or may not be less, or more, desirable. High costs also attract a less desirable outcome, but differences are compared relative to each other. A relatively high cost where the cost by difference would be an order of magnitude higher than the lowest cost option therefore would be coloured red, a less than order of magnitude higher cost would be coloured orange and the lowest cost option would be coloured green. It should be noted that societal assessment examined at beneficial outcomes as well as detrimental outcomes. Where comparison of options varies by shades of green rather than by red or orange it means there is little to choose between the options.

**Criteria and sub-criteria for pipelines, umbilicals, and cables**

| Criteria       | Definition   | Sub-criteria (Short-term & Legacy)  | Comments  |
|----------------|--|---|---|
| Technical      | A technical evaluation of the complexity of a job that can be expected to proceed without major consequence or failure if it is adequately planned and executed.                                       | Risk of project failure.  | Assesses the chances of failure, whether equipment is available, maturity of the associated technology, any integrity concerns, and would contingency planning be needed?   |
|                |  | Technological challenge.  |   |
|                |  | Technical challenge.  |   |
| Safety         | An assessment of the potential health and safety risk to people directly or indirectly involved in the programme of work offshore and onshore, or who may be exposed to risk as the work is conducted. | Health and safety risks for project personnel conducting decommissioning activities offshore.                           | Assesses typical offshore and onshore hazards. Offshore hazards include loss of dynamic positioning, sudden movements during mattress recovery works, dropped objects, collision between vessels. This would vary with the quantity of material being recovered. After decommissioning has been completed typical hazards could relate to exposed mattresses, or pipelines leading to possibility of snagging of fishing nets. Onshore hazards might include dealing with large quantities of bulk items, onshore cutting, or crushing, sudden movements or dropped objects and these would increase with the quantity of material being handled. |
|                |  | Residual risks to marine users on successful completion of decommissioning.   |   |
|                |  | Safety risks for project personnel engaged in conducting decommissioning activities onshore.                            |   |
| Environmental  | An assessment of the significance of the threats or impacts to the environmental receptors because of operational activities or the legacy aspects.  | Energy and emissions to atmosphere.   | The pipelines are not located inside an environmentally sensitive area. Where applicable, assesses the effect on the seabed, the effect on the conservation objectives, extent of temporary and permanent disturbance, noise considerations, type of material being left <i>in situ</i> , compares fate of materials, requirement for materials needing to be manufactured to compensate for materials left <i>in situ</i> .  |
|                |  | Effect on seabed: Seabed disturbance and area affected.   |   |
|                |  | Disturbance to protected areas & impact on conservation objectives of the area  |   |
|                |  | Effect on water column: <ul style="list-style-type: none"> <li>• Liquid discharges to sea.</li> <li>• Noise.</li> </ul> |   |
|                |  | Waste creation and use of resources such as landfill. Recycling and replacement of materials.                           |   |
| Socio-economic | An assessment of the significance of the impacts on societal activities, including offshore and  | Effects on commercial activities e.g., fishing  |   |



| Criteria and sub-criteria for pipelines, umbilicals, and cables |   |   |  |
|---|---|---|--|
| Criteria  | Definition  | Sub-criteria<br>(Short-term & Legacy)   | Comments   |
|   | onshore activities associated with the complete programme of work for each option and the associated legacy impact. This includes all the “direct” societal effects (e.g., employment on vessels undertaking the work) as well as “indirect” societal effects (e.g., employment associated with services in the locality to onshore work scope, accommodation, etc.). | Employment.<br>Communities or impact on amenities.  | Decommissioning of infrastructure involves work that is temporary. Assesses impact on commercial activities and job creation.  |
| Cost  | Difference in cost.   | Difference in cost compared for like-for-like activities. Normalised to demonstrate a sense of scale. | Examines cost by difference for the complete removal and leave <i>in situ</i> options. Common activities such as engineering and management costs, mobilisation and demobilisation of the same vessels are ignored in the assessment. All other criteria and sub-criteria being equal, cost would be the final differentiator. |

**Table 4.1.1: Pipelines comparative assessment method – criteria & sub-criteria**

## 6 COMPARATIVE ASSESSMENT

### 6.1 Technical Considerations

It would be technically feasible to recover all the pipelines. The method used would depend on size, the material of manufacture, and whether a pipeline is concrete weight coated. The removal of the surface laid sections either side of the sections buried under rock would most likely be removed using the 'cut and lift' method, because the water depth and relatively short lengths of flowlines and umbilicals being recovered would not be conducive to recovery using the 'reverse reel' method. However, the 'reverse reel' method would likely be achievable once the flowlines and umbilicals have been fully exposed, with the concrete mattresses having been removed and overlying rock dispersed. Once 'reverse reel' operations are underway, the recovery process is more efficient than that of the 'cut and lift' method.

There is existing technology available, and the technical challenges are not significant, so the risk of project failure is small. Excepting the need to deal with overlying rock for those pipelines that are buried, the decommissioning activities are all an extension of those required to remove the surface laid sections. The rock could either be removed using standard dredging methods suitable for the water depths around Solan or be dispersed using an MFE.

Pipelines have been left *in situ* and buried under rock before without issue from a technical perspective.

### 6.2 Safety Considerations

The difference in potential safety risk between the options is such that a HAZID was not considered necessary at this stage. A HAZID would ordinarily be conducted as part of the preparatory activities.

#### **Safety risk to offshore project personnel**

For the complete removal option, the removal or dispersal of rock would be performed using remotely operated equipment. Apart from this activity, the decommissioning activities would be an extension of those required for the removal of the surface laid pipelines and protection and stabilisation features. Although PL3095<sup>3</sup> (and PL3094, not addressed in this comparative assessment) would be removed using the 'cut and lift' method, the removal of all other flowlines and umbilicals could be achieved using the 'reverse reel' method. This means that there would be less repetitive material handling for the complete removal option. For the leave *in situ* option, the pipeline ends would otherwise be removed using the 'cut and lift' method.

Irrespective of which decommissioning option adopted, PL3095 would be removed using the 'cut and lift' method. This means that the removal of the short 204m long section currently buried under rock can be viewed as an extension of the activities needed to remove the surface laid sections of the pipeline.

The flexible flowlines and umbilicals would be removed using the 'reverse reel' method and this can be viewed as a safer and more efficient activity, involving less material handling than the 'cut and lift' method. The 'cut and lift' method would otherwise be used for removing the surface laid end sections.

- PL3095. Risk associated with 'cut and lift' operations. Assuming PL3095 would be excavated from burial under 2.3m of rock, from a technical perspective the removal operation should be relatively straightforward. The complete removal option would be an extension of the removal of the surface laid sections. To ensure road transportable lengths of between 10m and 12m, the 'cut and lift' operations would require between ~80 to ~100 sections of pipe to be removed *per km* of pipeline; the section buried under rock would not be a significant addition to the scope (1,317m vs. 1,521m). From a safety perspective, the addition to the removal scope would not be significant. The associated risks would increase with the number of operations needing to be performed, but the work is repetitive and can be considered routine for the lengths being considered here.

---

<sup>3</sup> Excluding the offloading hose that would likely be reverse reeled

- PL3095. The risk to all activities due to adverse weather would be marginally greater than for the leave *in situ* option as the vessels would be in the field for slightly longer.
- Flowlines and umbilicals (i.e. excl. PL3095). For the leave *in situ* option the pipeline ends would be removed using the 'cut and lift' method because a combination of water depth and length recovered would mean that the pipeline ends could not be removed using the 'reverse reel' method. However, the 'reverse reel' method could be used for removal of the full length of the flowline. Complete removal using the 'reverse reel' method would involve fewer moving parts from a material handling perspective and would be preferred from an offshore safety perspective.
- Flowlines and umbilicals (i.e. excl. PL3095). All risks associated with reverse reeling operations (i.e. complete removal). The risks to personnel would probably be less than incurred when using the 'cut and lift' method for leave *in situ*.
- Flowlines and umbilicals (i.e. excl. PL3095). The risks associated with the vessel being attached to the pipeline during 'reverse reel' operations (i.e. complete removal) would be slightly higher than for the 'cut and lift' operations associated with leave *in situ*.
- Flowlines and umbilicals (i.e. excl. PL3095). The risk to all activities due to adverse weather would be marginally greater for the leave *in situ* option because the recovery vessels would be in the field for slightly longer when using the 'cut and lift' method. The 'reverse reel' method would a quicker recovery rate per km than the 'cut and lift' method.
- For the complete removal option, the recovery of the deposited rock using any suitable dredging method would take longer than dispersal using an MFE. Both operations could be achieved using remote operations underwater, but this is where the similarity ends. Recovery of rock to a suitable vessel would introduce material handling requirements that would not be needed when using an MFE, and so would be not preferred from safety perspective. The recovery or dispersal of rock would not be required for the leave *in situ* option.
- Risk associated with legacy survey activities. The risk associated with vessels being used for legacy type pipeline surveys in future would be greater for the leave *in situ* option than for complete removal. The operational risks are such that any safety concerns would be low, but to have to conduct the operation at all would present more of a risk than doing nothing. Typically, in the UK a minimum of three legacy surveys would be required to confirm the condition of subsea pipelines left *in situ*. Arguably the risk associated with legacy activities would be disproportionately high because the lengths buried under rock are short (2.976km) and relatively close to each other. Notwithstanding any impacts from adverse weather in the field, mobilisations and transit to the field would take likely take longer than the actual pipeline survey work.

### Short-term safety risk to fishermen and other marine users

The risk to mariners in the short-term is aligned with the duration of activities in the field. Except for transits to and from the Solan field, and the execution of work on PL3095 on a short section of pipeline buried under 204m long rock (Figure B.1.1) the decommissioning activities would all be conducted inside the 500m safety zone.

For PL3095, while decommissioning operations are underway the duration of vessels in the field would be slightly longer for the complete removal option than for leave *in situ*. This is because the complete removal works would be an extension of the removal works for the surface laid sections.

For the rest of the flowlines and umbilicals (i.e. excl. PL3095) once the concrete mattresses have been removed and the rock dispersed, recovery using the 'reverse reel' method would take less time than the 'cut and lift' method that would otherwise be used for the pipeline ends.

Any vessel equipped with an MFE could temporarily move away from location relatively unhindered. A dredging vessel could also temporarily move away from location but there would be an increased threat of vessel collision should other vessels be present in the area. The risk of collision would, however, be small to negligible.

From the perspective of risk to fishermen and other marine users, the difference between the decommissioning options is not significant because most of the work would be done inside the 500m safety zones while they remain operational.

### Residual safety risk to fishermen and other marine users

The greatest risk relating to marine users was likely to be concerned with snagging of fishing gear, specifically demersal trawl boards. For demersal trawling activities there is a potential for snagging on equipment left on the seabed, including spoil mounds and pipelines that remain on the seabed after decommissioning activities have been completed. In this instance, for the leave *in situ* option, once the surface laid ends have been dealt with, and the ends buried, the remaining pipelines can be expected to remain buried with no exposures. Although buried, that the cut pipeline ends would remain *in situ* and potentially become exposed in future. This situation would present a potential snagging risk that would not exist should the pipelines be fully removed.

The grade of rock (section 2.4.7) is such that should it be dispersed, it should not present a snagging hazard to demersal trawling activities, but this would best be verified by overtrawl.

Either option would be subject to verification of a clear seabed that is free of snag hazards once decommissioning works had been completed.

### Health & safety risk to onshore project personnel

More material would be recovered to shore for the complete removal option. This means that for the complete removal option more material would need to be dealt with than for the leave *in situ* option. Another difference is the way that the materials arrive to the onshore location.

For the complete removal option PL3095 would be shipped to shore with the recovered pipe transported and lifted in bundles, whereas the flowlines and umbilicals would be brought to shore on pipeline reels.

For the leave *in situ* option all the pipelines, flowlines and umbilicals will be transported and lifted in bundles of pipe resulting in more material handling and individual transfers to shore.

The total length recovered for each of the decommissioning options is summarised in Table 6.2.1:

| Solan pipeline recovery methods & quantities |                  |                  |                      |                  |
|--|------------------|------------------|----------------------|------------------|
| Pipeline ID                                  | Complete removal |                  | Leave <i>in situ</i> |                  |
|  | Cut & Lift (m)   | Reverse Reel (m) | Cut & Lift (m)       | Reverse Reel (m) |
| PL3095                                       | 1,521            | n/a              | 1,317                | n/a              |
| PL3580                                       | n/a              | 538              | 238                  | n/a              |
| PL3581                                       | n/a              | 596              | 236                  | n/a              |
| PL3582                                       | n/a              | 612              | 252                  | n/a              |
| PL3583                                       | n/a              | 577              | 277                  | n/a              |
| PLU3585                                      | n/a              | 538              | 238                  | n/a              |
| PLU3586                                      | n/a              | 594              | 234                  | n/a              |
| PL4971                                       | n/a              | 1,097            | 181                  | n/a              |
| PLU4972                                      | n/a              | 1,463            | 267                  | n/a              |
| <b>Σ above</b>                               | <b>1,521</b>     | <b>6,015</b>     | <b>3,240</b>         | <b>n/a</b>       |
| <b>Σ above</b>                               |                  | <b>7,536</b>     |                      | <b>3,240</b>     |
| <b>All infrastructure</b>                    |                  | <b>10,714</b>    |                      | <b>7,738</b>     |

**Table 6.2.1 Quantity recovered for each option and (likely) method**

The threat to safety of onshore personnel posed by each of the two decommissioning options at the waste disposal site can be differentiated as follows:

- Unloading cut pipes from a vessel has been done before, and for the pipelines considered in this assessment the length of pipelines being recovered using 'cut and lift' would be more than twice that recovered for the complete removal option (Table 6.2.1). This means that the threat to safety associated with transferring pipe bundles to shore would be higher for the leave *in situ* option.
- For items that are transported on a pipeline reel the potential for dropped objects would be less than for the larger number of pipeline bundles.
- To ensure road transportable lengths of between 10m and 12m, the 'cut and lift'; operations would require between ~80 to ~100 sections of pipe to be removed per km of pipeline whereas one reel would be used for each pipeline recovered using the 'reverse reel' method. This means that for the leave *in situ* option there would be a much higher number of individual items being transferred to shore and (possibly) transported by road.
- Once onshore, the component parts would be separated using mechanised equipment or automated fragmentisers or shredders<sup>4</sup>. The procedures for these processes are well managed, although the increased volume of material for the complete removal option would increase the potential threat to safety of personnel compared to the leave *in situ* option.
- Unspooling of pipelines and umbilical from a reel has been done before but assuming that this would be done using a mostly automated process the threat to safety of onshore personnel would be less for the complete removal option than for the leave *in situ* option.

Onshore activities would be mechanised as far as it would be practicable to do so, and procedures would be put in place to deal with the material safely. The safety risk to onshore personnel would increase with the quantity of material being managed, so theoretically the complete removal method could present a higher threat to the safety of onshore personnel, but fewer pipeline bundles would need to be dealt with.

On balance therefore, the complete removal option would likely pose less of a threat to the safety of onshore personnel than the leave *in situ* option: the complete removal option would be preferred although the difference is not significant.

## 6.3 Environmental Considerations

### Planned energy use, emissions, and discharges

Including the surface laid sections, the duration that vessels would be required in the field for the complete removal option would be less than required for leave *in situ*. This is because only PL3095 (and PL3094 which is not included in this assessment) would be completely removed using the 'cut and lift' method. All the flexible flowlines and umbilicals would be recovered using 'reverse reel' method, and this is a quicker and far more efficient recovery process. This means that on balance for offshore operations the planned energy use would be less for the complete removal option. Energy would be used to process the materials recovered to shore, but this would be offset by the energy savings associated with recycling material rather than creating new materials.

### Planned impacts on the seabed sediments

Theoretically, the complete removal option would result in no materials left in the seabed, although when removing concrete coated pipelines it is likely that the concrete coating will spall or break off during the removal operations. Despite best intentions some of this material may be left *in situ*.

The leave *in situ* option would result in materials being left to degrade naturally. The pipelines (PL3095 (and PL3094, but this pipeline is not included in this assessment) are predominantly manufactured from steel and

---

<sup>4</sup> <https://www.reutersevents.com/oilandgas/projects-and-technologies/john-lawrie-decommissioning-just-got-greener>

concrete so this would not be detrimental to the local environment. The deposition of degraded concrete and steel materials would likely occur very gradually over tens if not hundreds of years [3].

The composite flowlines and umbilicals have a higher content of composite materials (~15% to ~20%) and so would take much longer than steel to decompose. The deposition of the composite materials into the marine environment would also likely occur very gradually over hundreds of years, and so would cause little detriment to the local marine environment.

For demonstrative purposes if we assume that the removal of all the pipelines included in this assessment would affect a 10m wide corridor, and the associated rock dispersed over a corridor 30m wide (60m wide corridor for PL3095 due to the height of the rock berm), the overall area of seabed impacted would be as indicated in Table 6.3.1. The ratio of seabed impacted by complete removal operations in the short-term would be 5.6x larger than the leave *in situ* option (0.116/0.021 = 5.6). Nevertheless, the area of seabed impacted in the short-term would be extremely small (0.004% for complete removal) when compared to the average area of the ICES rectangles (3,109km<sup>2</sup>, section 2.4.3).

| Solan pipeline removal – area of seabed affected (short-term operations) |                  |              |                                 |                      |                                 |
|--|------------------|--------------|---------------------------------|----------------------|---------------------------------|
| Pipeline ID  | Complete removal |              |                                 | Leave <i>in situ</i> |                                 |
|  | Length (m)       | Rock (m)     | Area affected (m <sup>2</sup> ) | Length (m)           | Area affected (m <sup>2</sup> ) |
| PL3095   | 1,391            | 204          | 24,110                          | 1,317                | 13,170                          |
| PL3580   | 408              | 300          | 4,080                           | 238                  | 2,380                           |
| PL3581   | 466              | 360          | 4,660                           | 236                  | 2,360                           |
| PL3582   | 482              | 360          | 4,820                           | 252                  | 2,520                           |
| PL3583   | 447              | 300          | 4,470                           | 277                  | 2,770                           |
| PLU3585  | 408              | 300          | 4,080                           | 238                  | 2,380                           |
| PLU3586  | 464              | 360          | 4,640                           | 234                  | 2,340                           |
| PL4971   | 967              | 916          | 27,990                          | 181                  | 1,810                           |
| PLU4972  | 1,333            | 1,196        | 37,250                          | 267                  | 2,670                           |
| <b>Σ above (m, m<sup>2</sup>)</b>  | <b>7,536</b>     | <b>4,296</b> | <b>116,100</b>                  | <b>3,240</b>         | <b>20,700</b>                   |
| <b>Σ above (km, km<sup>2</sup>)</b>                                      | <b>7.536</b>     | <b>4.296</b> | <b>0.116</b>                    | <b>3.240</b>         | <b>0.021</b>                    |

**NOTES**

- The length of pipeline includes length of riser (130m). The area affected *excludes* the length of the risers.
- PL3095. The rock profile is 20m wide (Figure 3.5.2). Therefore, for complete removal it is assumed that the PL3095 the associated rock would be dispersed over a corridor 60m wide. Example calculation for PL3095: area affected = (1,317-130 (assumed length of riser)) x 10 + 204 x 60 = 24,110m<sup>2</sup>.
- PL3580, PL3583 and PLU3585 share the same rock (300m long) therefore 1/3 of area (300 x 30/3 = 3,000m<sup>2</sup> per pipeline) is affected. Example calculation for the complete removal of PL3580: area affected = (238-130) x 10 + 300 x 30 / 3 = 1,080 + 3,000 = 4,080m<sup>2</sup>.
- PL3581, PL3582 and PL3586 share the same rock (360m long) therefore 1/3 of area (360 x 30/3 = 3,600m<sup>2</sup> per pipeline) is affected. Example calculation for the complete removal of PL3581: area affected = (236-130) x 10 + 360 x 30 / 3 = 1,060 + 3,600 = 4,660m<sup>2</sup>.
- For 'leave *in situ*' the area is calculated by multiplying the length of pipeline recovered x 10m. For simplicity, the 10m wide corridor accounts for the disturbance to the seabed due to the removal of the concrete mattresses.

**Table 6.3.1 Area of seabed disturbed during recovery operations (short-term)**

If we assume that the complete removal of a pipeline would result in the dispersed rock being left *in situ* afterwards affecting a 30m wide corridor (60m wide corridor for PL3095 due to height of rock berm), the overall area of seabed impacted would be as indicated in Table 6.3.1. The area impacted would be 3x larger than the area affected by leaving the rock in its original location. Nevertheless, the area of seabed impacted over the longer-term would be extremely small (0.003% for complete removal) when compared to the average area of the ICES rectangles (3,109km<sup>2</sup>, section 2.4.3).

| Solan pipeline removal – area of seabed affected (long-term) |                  |              |                                 |                      |                                 |
|--|------------------|--------------|---------------------------------|----------------------|---------------------------------|
| Pipeline ID  | Complete removal |              |                                 | Leave <i>in situ</i> |                                 |
|  | Length (m)       | Rock (m)     | Area affected (m <sup>2</sup> ) | Rock length (m)      | Area affected (m <sup>2</sup> ) |
| PL3095   | 0                | 204          | 12,240                          | 206 (20m wide)       | 4,121                           |
| PL3580   | 0                | 300          | 9,000                           | 303 (10m wide)       | 3,030                           |
| PL3581   | 0                | 360          | 3,600                           | 364 (10m wide)       | 3,636                           |
| PL3582   | 0                | As PL3581    | As PL3581                       | As PL3581            | As PL3581                       |
| PL3583   | 0                | As PL3580    | As PL3580                       | As PL3580            | As PL3580                       |
| PLU3585  | 0                | As PL3580    | As PL3580                       | As PL3580            | As PL3580                       |
| PLU3586  | 0                | As PL3581    | As PL3581                       | As PL3581            | As PL3581                       |
| PL4971   | 0                | 916          | 27,480                          | 925 (10m wide)       | 9,252                           |
| PLU4972  | 0                | 1,196        | 35,880                          | 1,208 (10m wide)     | 12,080                          |
| <b>Σ above (m, m<sup>2</sup>)</b>                            | <b>0</b>         | <b>2,976</b> | <b>95,400</b>                   | <b>3,006</b>         | <b>32,118</b>                   |
| <b>Σ above (km, km<sup>2</sup>)</b>                          | <b>0</b>         | <b>2.976</b> | <b>0.095</b>                    | <b>3.006</b>         | <b>0.032</b>                    |

**NOTES**

1. Complete removal. Assumes that once dispersed, the rock would be left *in situ*. Example calculation for area impacted over the long-term for PL3095: 204 x 60 = 12,240m<sup>2</sup>.
2. Leave *in situ*. Assumes length increased by a nominal 1% to account for rock deposited over cut pipeline ends. Example calculation for PL3095: 1.01 x 204 x 20 = 4,121m<sup>2</sup>.

**Table 6.3.2 Area of seabed disturbed during recovery operations (long-term)**

Based on the forgoing in the short-term and long-term the complete removal option would result in the spreading of a non-native substrate over a larger area of seabed than the leave *in situ* option, but in both cases the area impacted is negligible compared to the average area of the affected ICES rectangles. Over time the local flora and fauna can be expected to colonise the newly dispersed rock at no detriment to the local environment.

### Waste management

The amount of material made available for reuse, recycling or destined for landfill would be related to the quantity recovered. However, experience would suggest that little material would be destined for landfill once recovered. The concrete weight coating would likely be crushed and recycled along with the steel material. The material used for flexible flowlines and umbilicals that are recovered as part of a decommissioning programme. can theoretically be reused but in practice the materials would have suffered deformation during the recovery process. Proving that the integrity of the complex multi-layered structure of such components has not been compromised during the handling and operational process can sometimes be difficult, and often recycling is the only realistic option.

Assuming the flowlines and umbilicals recovered would not be reused as they are<sup>5</sup>, for both decommissioning options the recovered material would need to be stripped into material components. Materials such as steel and copper can be readily recycled as the base material, while synthetic components would usually be recycled as recovered energy.

The key to good recycling is the ability to separate out the various component parts, thereby removing any cross-contamination which would otherwise result in the recovered product being unsuitable for recycling. Flexible flowlines and umbilicals are constructed with several metallic and non-metallic layers. These can be separated into their constituent parts using a largely mechanical process.

<sup>5</sup> Flowlines, umbilicals, and their duty are individually specified. These would need to be replicated for the flowlines and umbilicals to be suitable for reuse. Experience would suggest that this would be unlikely.

Umbilicals pose a bit more of a challenge as they do not separate out very easily. However, by processing these through automated fragmentisers or shredders these can be separated, and the metallic content extracted for recycling.

The complete removal option would result in all the materials being recovered to shore for recycling and disposal whereas any material left *in situ* would need to be replaced by the manufacture of new material.

## 6.4 Societal Conditions

### Commercial

While the vessels are present in the field and activities are being undertaken the area would not be accessible for fishing. Therefore, the magnitude of the impact on commercial activities would be related to the number and duration of vessels. However, apart from transits to and from the field that are well managed and routine, apart from a short length of PL3095 (204m long, buried under rock (Figure B.1.1)) extending between 500m safety zones all the decommissioning activities will be conducted inside a 500m safety zone. Therefore, from a commercial perspective there is nothing to differentiate the options.

The main commercial activity in the area is a mixture of pelagic, demersal, and shellfish fishing. Once the infrastructure has been removed the area would be available for commercial fishing. Conservatively, if we assume that the areas covered by rock could not be fished, for the complete removal option the area of seabed that would permanently be impacted because of rock being dispersed would be 0.095km<sup>2</sup> vs. 0.032km<sup>2</sup> (Table 6.3.2) should the rock be left undisturbed as for the leave *in situ* option. The rock covering would only restrict the area of seabed available for demersal (£1,216.82/km<sup>2</sup>) and shellfish (£70.02/km<sup>2</sup>) fishing, and by inspection this would have an almost negligible effect on the value of fish landed from the area.

Therefore, the complete removal option would have a slightly larger adverse impact on commercial fishing activities in the area, but for both options the impact is negligible.

### Employment

**Offshore.** On balance the leave *in situ* option would take longer to achieve because the pipeline ends would be removed using the 'cut and lift' method. Therefore, this option would therefore impact more positively on employment than complete removal for offshore activities.

**Onshore.** The complete removal option will result in 7.536km of pipelines<sup>6</sup> being recovered to shore vs. 3.240km for leave *in situ*. The collective recovery of all the pipelines in the Solan area could result in creation of new jobs, although they might only be short-term. The significance of the positive impact can, however, be assessed as low.

### Communities

The port and the disposal site have yet to be established. However, they would be existing sites which are used for oil and gas activities and hold the required permits for waste management. The communities around the port and the waste disposal sites are therefore expected to have adapted to the work required and the decommissioning activities associated with this project would be an extension of the existing situation. Therefore, the effect on communities is not considered a significant differentiator between options.

## 6.5 Cost considerations

More details of the cost assessment by difference for the pipelines are presented in Appendix D, Table D.3.1.

The differences in cost are driven by:

---

<sup>6</sup> Quantities are based in this assessment only. The overall length of pipelines, flowlines, umbilicals, etc. is 10.714km.



- For both decommissioning options, the concrete mattresses would be removed before the pipelines are recovered.
- For the leave *in situ* option the surface laid ends would be removed using the 'cut and lift' method.
- For the complete removal method, the rock would be dispersed to enable access to remove the otherwise buried pipelines.
- For complete removal PL3095 would be removed using the 'cut and lift' method whereas all the other flowlines and umbilicals would be removed using 'reverse reel' which is a more efficient process.

For these reasons, as PL3095 would be removed using the 'cut and lift' method, it would cost less to leave the section buried under rock *in situ*. However, the increase in decommissioning effort to recover the section buried under rock (204m) would be small.

Except for PL4971 and PLU4972, for all the other flowlines and umbilicals the complete removal option would cost less than the leave *in situ* option, even accounting for the rock dispersal operations. The complete removal of PL4971 and PLU4972 would cost slightly more than leave *in situ*. This is because once the protection and stabilisation features have been removed and the overlying rock dispersed, the products could be recovered using the 'reverse reel' method which is more efficient than 'cut and lift'. The reason for PL4971 & PLU4972 costing slightly more is because there would be a relatively short length and few mattresses to be recovered at the ends.

In all instances, the cost of the most expensive option is less than 2x the cost of the cheapest option.

## **7 CONCLUSIONS AND RECOMMENDATIONS**

### **7.1 Conclusions**

For the purposes of this comparative assessment it is assumed that the following pipelines will be fully removed as per mandatory requirements for surface laid infrastructure: PL3094, PL3578, PL3579, PLU3584, PLU3585JW2, PLU3586JW1, PLU4204, PLU4205, PLU4206, PLU4207, PLU4208, PLU4209, PL4973, PL4974, PL4975, PLU4976, and PL4977.

To varying extents the following pipelines are buried under rock. PL3095 (204m), PL3580 PL3583, PLU3585 (300m, shared), PL3581, PL3582, PLU3586 (360m, shared), PL4971 (916m), and PLU4972 (1,196m). This comparative assessment compares the complete removal and leave *in situ* decommissioning options for those sections of the pipelines that are buried under deposited rock but takes account of the methods used to remove the surface laid sections. This is because in many instances the pipeline might be completely removed more efficiently than the surface laid ends or the removal operations for the complete pipeline may be an extension of the removal of the surface laid ends.

The assessment found that for both options it would be technically feasible to remove all the pipeline infrastructure, and that the technology is available and that the threat of project failure was low. For PL3095 the complete removal option would be an extension to the leave *in situ* option. The whole pipeline would be removed using the 'cut and lift' method. Once the concrete mattresses have been removed and the rock dispersed, the flexible flowlines and umbilicals could be removed using the 'reverse reel' method and this would be a more efficient removal process than 'cut and lift'.

The safety assessment found that on balance it would be safer to completely remove the pipelines. This is because the subsea work would mostly be conducted using remotely operated equipment. Once exposed (i.e. concrete mattresses removed and rock dispersed) most of the pipelines except PL3095 could be removed using the 'reverse reel' method rather than 'cut and lift' which would otherwise be used for the surface laid ends. Most of PL3095 would be removed using the 'cut and lift' method anyway, and the removal of the section buried under rock would be a short extension of what would already be repetitive work. For the flexible flowlines and umbilicals adoption of the complete removal option would mean that the product could be recovered using the 'reverse reel' method. This would lead to a decrease in the number of bundles of pipe being transferred on the deck of the vessel and to shore, because just one pipeline reel would likely be used per pipeline. Onshore activities would be mechanised as far as it would be practicable to do so, and procedures would be put in place to deal with the material safely. The safety risk to onshore personnel would increase with the quantity of material being managed, so theoretically the complete removal method could present a higher threat to the safety of onshore personnel, but fewer bundles of pipe would need to be dealt with.

The environmental assessment found that the use of energy and emissions to air would be less for the offshore operations associated with the complete removal option because the 'reverse reel' method would take less time to execute than leave *in situ*, although more materials would be brought to shore, requiring energy to process. The complete removal option would result in more material being recovered to shore for recycling, either as raw material or recovered energy. It is unlikely any of the material recovered could be reused.

The complete removal option would require rock to be dispersed, and this hard substrate is not native to the seabed and although it would result in patchy smothering of the seabed, over time it would be colonised by the local flora and fauna. For the leave *in situ* option, the area of seabed already covered by rock is much smaller. In the short-term seabed impacted by complete removal operations in the short-term would be 3.9x larger than the leave *in situ* option. Longer term, the area impacted would be 3x larger than the area affected by leaving the rock in its original location. In both cases the area of seabed affected is extremely small when compared to the area of a local ICES rectangle, measured in thousandths of a percent.

For all pipelines, the complete removal option would theoretically result in no materials left in the seabed although it is likely small quantities of concrete will spall during the recovery of PL3095 (and PL3094), and

despite best intentions this material could be left on the seabed. However, the effect of this is not likely to be significant and spalling may occur anyway when removing the surface laid sections.

For all pipelines, the leave *in situ* options would result in materials buried under rock being left to degrade naturally. PL3095 is predominantly manufactured from steel and concrete. Degradation of such materials would not be detrimental to the local environment as the deposition of degraded concrete and steel materials would likely occur very gradually over tens if not hundreds of years [3]. The flowlines and umbilicals have a higher content of composite materials (~15% to 20%) and so the sections buried under rock would take much longer than steel to decompose. As the process would be slow, occurring very gradually over hundreds of years, the products of degradation would be at little detriment to the local marine environment.

Commercial fishing activities in the area use demersal, pelagic and shellfish trawling methods, and fishing effort seems to have been declining in importance since 2019.

In 2021, the average value of demersal, pelagic and shellfish landed per km<sup>2</sup> was £954.24, £482.79, and £114.97 reduced from £1,223.05, £1,929.07, and £70.79 obtained in 2021. These values are calculated by dividing the commercial value of fish landed by the average area of ICES rectangles 49E5, 49E6, 48E5 and 48E6) (3,109km<sup>2</sup>). The dispersal of rock or any rock left *in situ* undisturbed would have a negligible effect on demersal and shellfish effort, and no effect on pelagic trawling in the area.

Both the pipeline decommissioning options in the Solan area could result in creation of new jobs, but they might only be short-term. The significance of the positive impact is low.

For material that is brought to shore, the port and the disposal site would likely be existing sites which are used for oil and gas activities and hold the required permits for waste management. The effect on communities is not considered a significant differentiator between options.

As PL3095 would be removed using the 'cut and lift' method, it would cost less to leave the section buried under rock *in situ*. However, the increase in decommissioning effort to recover the section buried under rock (204m) would be small.

Except for PL4971 and PLU4972, for all the other flowlines and umbilicals the complete removal option would cost less than the leave *in situ* option, even accounting for the rock dispersal operations. This is because once the protection and stabilisation features have been removed and the overlying rock dispersed, the products could be recovered using 'reverse reel' which is a more efficient method than 'cut and lift'. The complete removal of PL4971 and PLU4972 would cost slightly more than leave *in situ*. The reason for this is because there would be a relatively short length and few mattresses to be recovered at the ends.

In all instances, the cost of the most expensive option is less than 2x the cost of the cheapest option.

## 7.2 Recommendations

The following recommendations arise from this comparative assessment:

- Completely remove the following surface laid pipelines as per mandatory requirements: PL3094, PL3578, PL3579, PLU3584, PLU3585JW2, PLU3586JW1, PLU4204, PLU4205, PLU4206, PLU4207, PLU4208, PLU4209, PL4973, PL4974, PL4975, PLU4976, and PL4977.
- Completely remove the following pipelines PL3095, PL3580, PL3583, PLU3585, PL3581, PL3582, PLU3586, PL4971 and PLU4972.

## **8 REFERENCES**

Please note the link names presented below have been abbreviated.

- [1] ABPmer (2018) Maritime 2017 AIS Average Weekly Density Shipping Data. Weblink last accessed 13 Sept 2022: [abpmer 2017 AIS Data](#)
- [2] Graham, C. Stewart, H.A. Poulton, C.V.L., James, J.W.C. (2001) A description of offshore gravel areas around the UK, British Geological Survey Commercial Report, CR/01/259. Weblink last access 02 August 20-22: [BGS CR-01-259.pdf](#)
- [3] HSE (Health and Safety Executive) (1997) The abandonment of offshore pipelines: Methods and procedures for abandonment. Offshore Technology report. HSE Books, Norwich. ISBN-7176-1421-2.
- [4] Marine Mammal Organisation (2022) UK sea fisheries annual statistics: Landings by rectangle and estimated EEZ. Weblink last accessed 17 Oct 2022: [UK-sea-fisheries-annual-statistics](#);
- [5] OPRED (2018) Offshore Oil and Gas Decommissioning Guidance Notes. Weblink last accessed 27 Jan 2020: [OPRED Guidance Notes Nov 2018](#);
- [6] Premier Oil (2021) Solon Decommissioning Programmes, AB-SO-LAP-LL-PM-PG-0001.
- [7] Premier Oil (2021) Solon Environmental Appraisal, AB-SO-XGL-LL-SE-RP-0001.

## APPENDIX A FLOWLINE AND UMBILICAL CONSTRUCTION

### Appendix A.1 Flowline construction

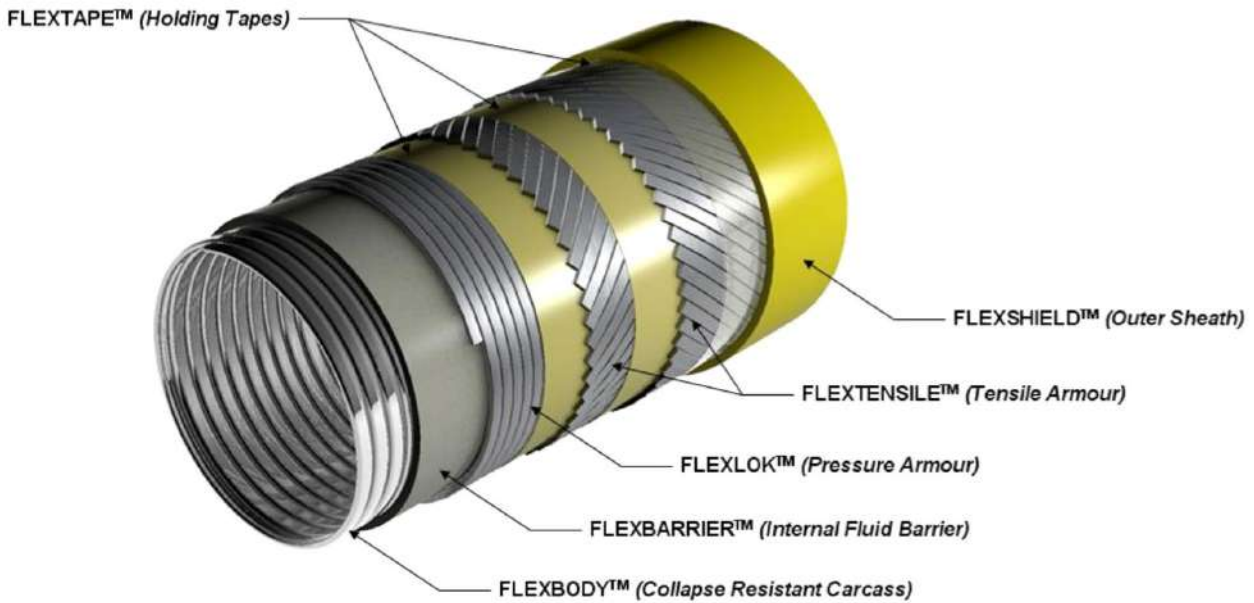


Figure A.1.1: Typical construction of flexible flowline

### Appendix A.2 SOST umbilical (PLU3584)

#### PLU3584 UMBILICAL CROSS-SECTION (STATIC)

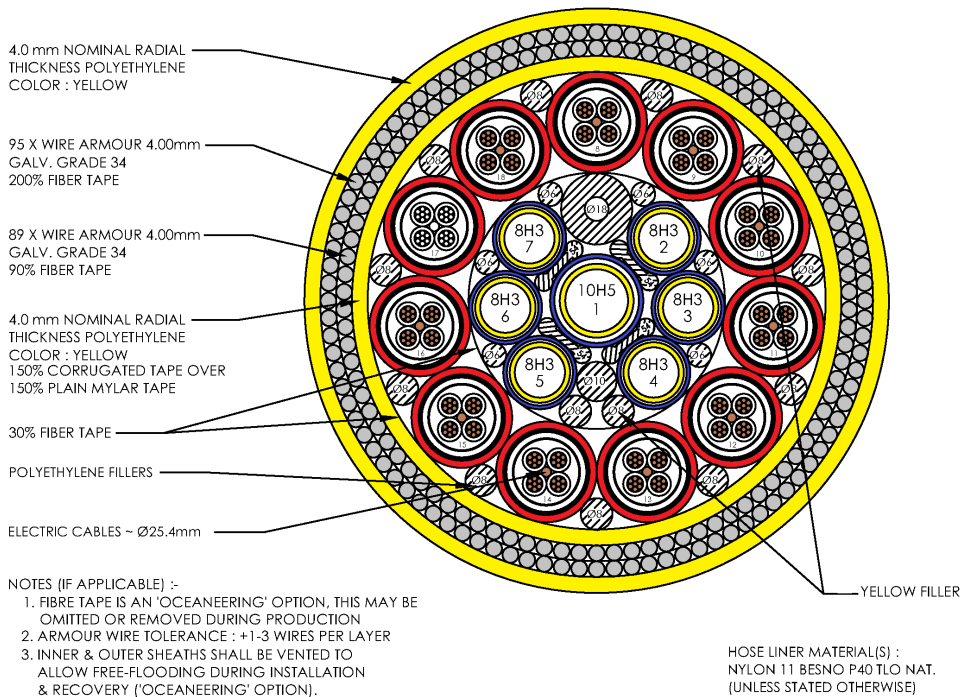
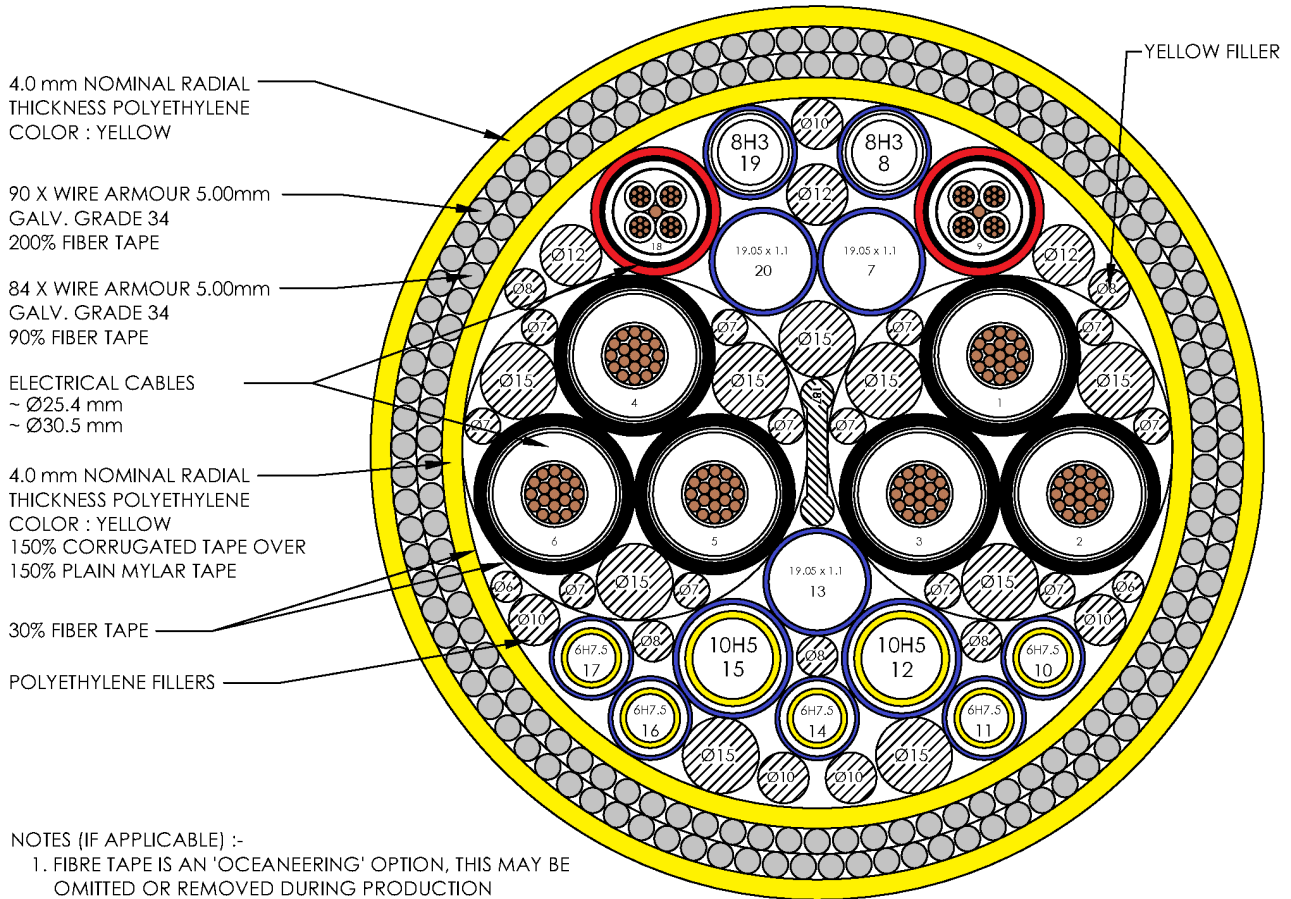


Figure A.2.1: SOST umbilical PLU3584 construction (146mm diameter)

**Appendix A.3 DC1 & DC2 umbilicals (PLU3585 & PLU3586)**

**PLU3585 UMBILICAL CROSS SECTION (DC1 STATIC)**



4.0 mm NOMINAL RADIAL THICKNESS POLYETHYLENE COLOR : YELLOW

90 X WIRE ARMOUR 5.00mm GALV. GRADE 34 200% FIBER TAPE

84 X WIRE ARMOUR 5.00mm GALV. GRADE 34 90% FIBER TAPE

ELECTRICAL CABLES ~ Ø25.4 mm ~ Ø30.5 mm

4.0 mm NOMINAL RADIAL THICKNESS POLYETHYLENE COLOR : YELLOW 150% CORRUGATED TAPE OVER 150% PLAIN MYLAR TAPE

30% FIBER TAPE

POLYETHYLENE FILLERS

YELLOW FILLER

NOTES (IF APPLICABLE) :-

1. FIBRE TAPE IS AN 'OCEANEERING' OPTION, THIS MAY BE OMITTED OR REMOVED DURING PRODUCTION
2. ARMOUR WIRE TOLERANCE : +1-3 WIRES PER LAYER
3. INNER & OUTER SHEATHS SHALL BE VENTED TO ALLOW FREE-FLOODING DURING INSTALLATION & RECOVERY

HOSE LINER MATERIAL(S) : NYLON 11 BESNO P40 TLO NAT. (UNLESS STATED OTHERWISE)

LINE NOS 7, 13 & 20 SUPER DUPLEX UNS S32750/60 OR UNS S39274 (UNLESS STATED OTHERWISE)

**PLU3586 UMBILICAL CROSS SECTION (DC2 STATIC) SIMILAR**

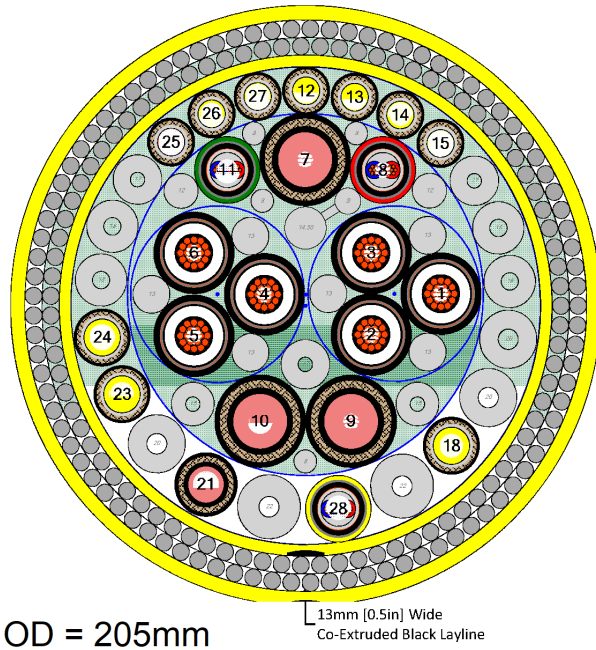
NOTES:-

1. OTHER THAN THE POSITION OF LINES 20 AND 7 THE DC1 AND DC2 UMBILICAL CROSS SECTION ARE IDENTICAL.

**Figure A.3.1: DC1 & DC2 umbilicals PLU3585 & PLU3586 construction**

### Appendix A.4 Well P3 umbilical PLU4972

#### PLU4972 UMBILICAL (WELL P3)



| Line # | Qty. | Component Type  |
|--------|------|---|
| 1      | 1    | 95mm <sup>2</sup> Single Core (Black) 28.4mm [1.118in] OD |
| 2      | 1    | 95mm <sup>2</sup> Single Core (Black) 28.4mm [1.118in] OD |
| 3      | 1    | 95mm <sup>2</sup> Single Core (Black) 28.4mm [1.118in] OD |
| 4      | 1    | 95mm <sup>2</sup> Single Core (Black) 28.4mm [1.118in] OD |
| 5      | 1    | 95mm <sup>2</sup> Single Core (Black) 28.4mm [1.118in] OD |
| 6      | 1    | 95mm <sup>2</sup> Single Core (Black) 28.4mm [1.118in] OD |
| 7      | 1    | 12H7.5 Permaliner - Core ID 19.05mm [0.75in]              |
| 8      | 1    | 10mm <sup>2</sup> TSPTA (Red) 23.3mm [0.917in] OD         |
| 9      | 1    | 12H7.5 Permaliner - Core ID 19.05mm [0.75in]              |
| 10     | 1    | 12H7.5 Permaliner - Core ID 19.05mm [0.75in]              |
| 11     | 1    | 10mm <sup>2</sup> TSPTA (Green) 23.3mm [0.917in] OD       |
| 12     | 1    | 6H7.5 Nylon 11 Besno P40 TLO - Core ID 9.525mm [0.375in]  |
| 13     | 1    | 6H7.5 Nylon 11 Besno P40 TLO - Core ID 9.525mm [0.375in]  |
| 14     | 1    | 6H7.5 Nylon 11 Besno P40 TLO - Core ID 9.525mm [0.375in]  |
| 15     | 1    | 6H7.5 Nylon 11 Besno P40 TLO - Core ID 9.525mm [0.375in]  |
| 16     | 0    | -   |
| 17     | 0    | -   |
| 18     | 1    | 8H5 Nylon 11 Besno P40 TLO - Core ID 12.7mm [0.5in]       |
| 19     | 0    | -   |
| 20     | 0    | -   |
| 21     | 1    | 8H7.5 Permaliner - Core ID 12.7mm [0.5in]                 |
| 22     | 0    | -   |
| 23     | 1    | 8H5 Nylon 11 Besno P40 TLO - Core ID 12.7mm [0.5in]       |
| 24     | 1    | 8H5 Nylon 11 Besno P40 TLO - Core ID 12.7mm [0.5in]       |
| 25     | 1    | 6H7.5 Nylon 11 Besno P40 TLO - Core ID 9.525mm [0.375in]  |
| 26     | 1    | 6H7.5 Nylon 11 Besno P40 TLO - Core ID 9.525mm [0.375in]  |
| 27     | 1    | 6H7.5 Nylon 11 Besno P40 TLO - Core ID 9.525mm [0.375in]  |
| 28     | 1    | 10mm <sup>2</sup> TSPTA (Yellow) 23.3mm [0.917in] OD      |

Figure A.4.1: Well P3 umbilical PLU4972 construction

### Appendix A.5 Well P3 6in hydraulic fluid fly-lead PLU4976

PLU4976 HYDRAULIC FLY-LEAD CROSS-SECTION

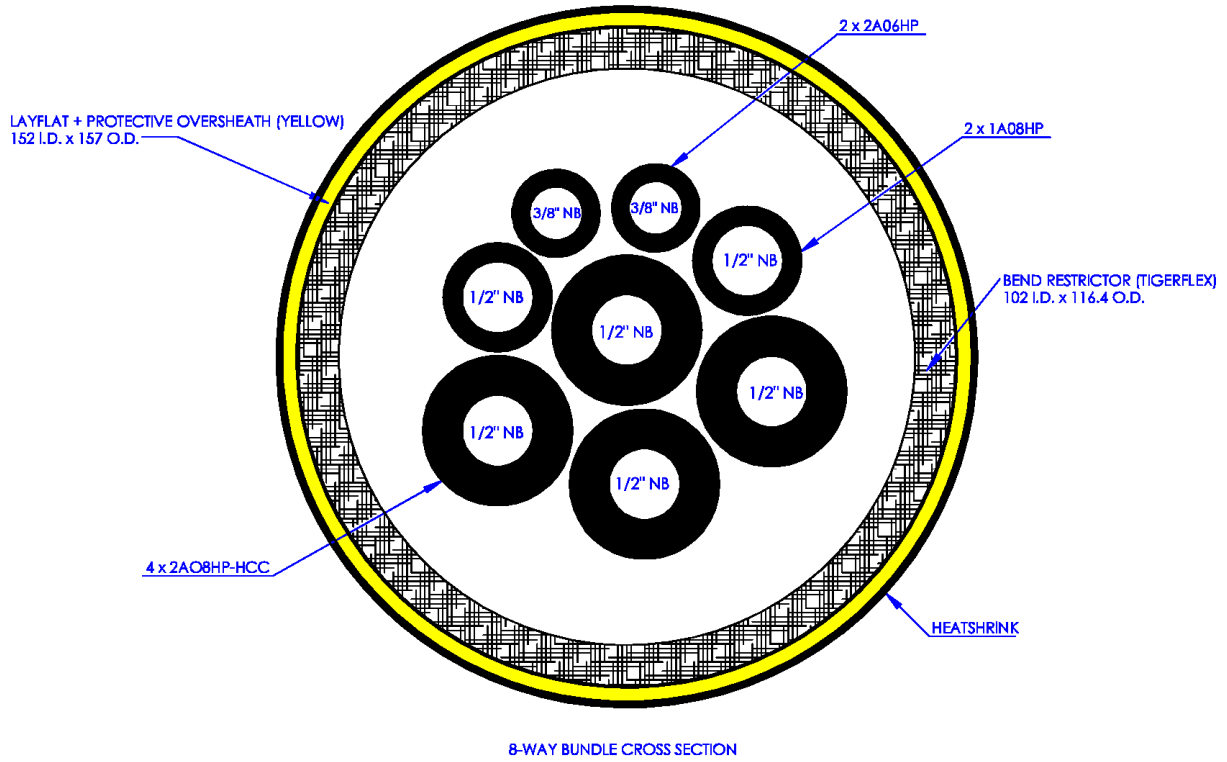


Figure A.5.1: Well P3 hydraulic fly-lead PLU4976 construction



## APPENDIX B SCHEMATICS

### Appendix B.1 Overview

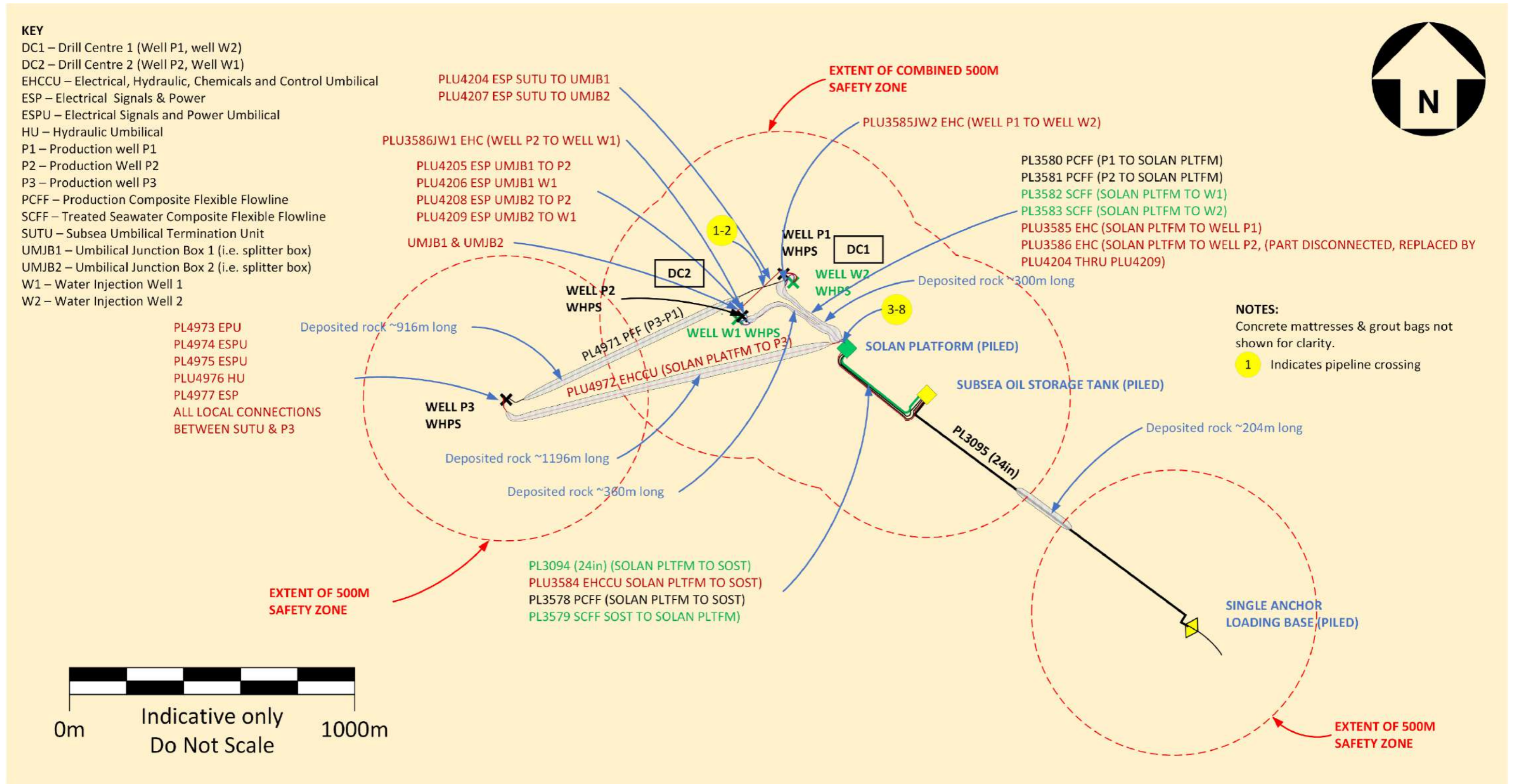


Figure B.1.1: Overview of infrastructure in Solan development area

## Appendix B.2 Solan platform

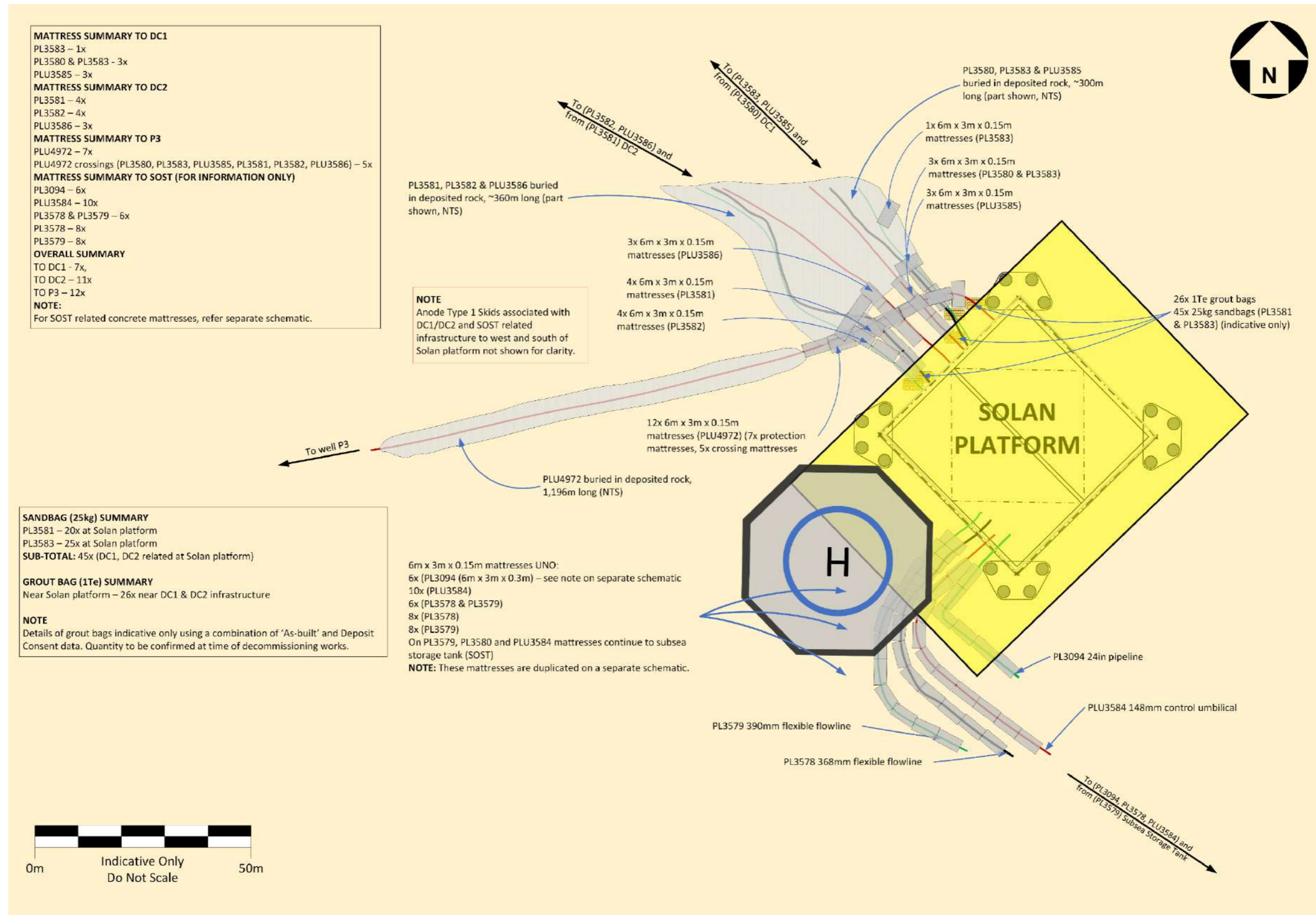


Figure B.21: Pipelines, flowlines & umbilicals at the Solan platform

### Appendix B.3 Solan platform & SOST

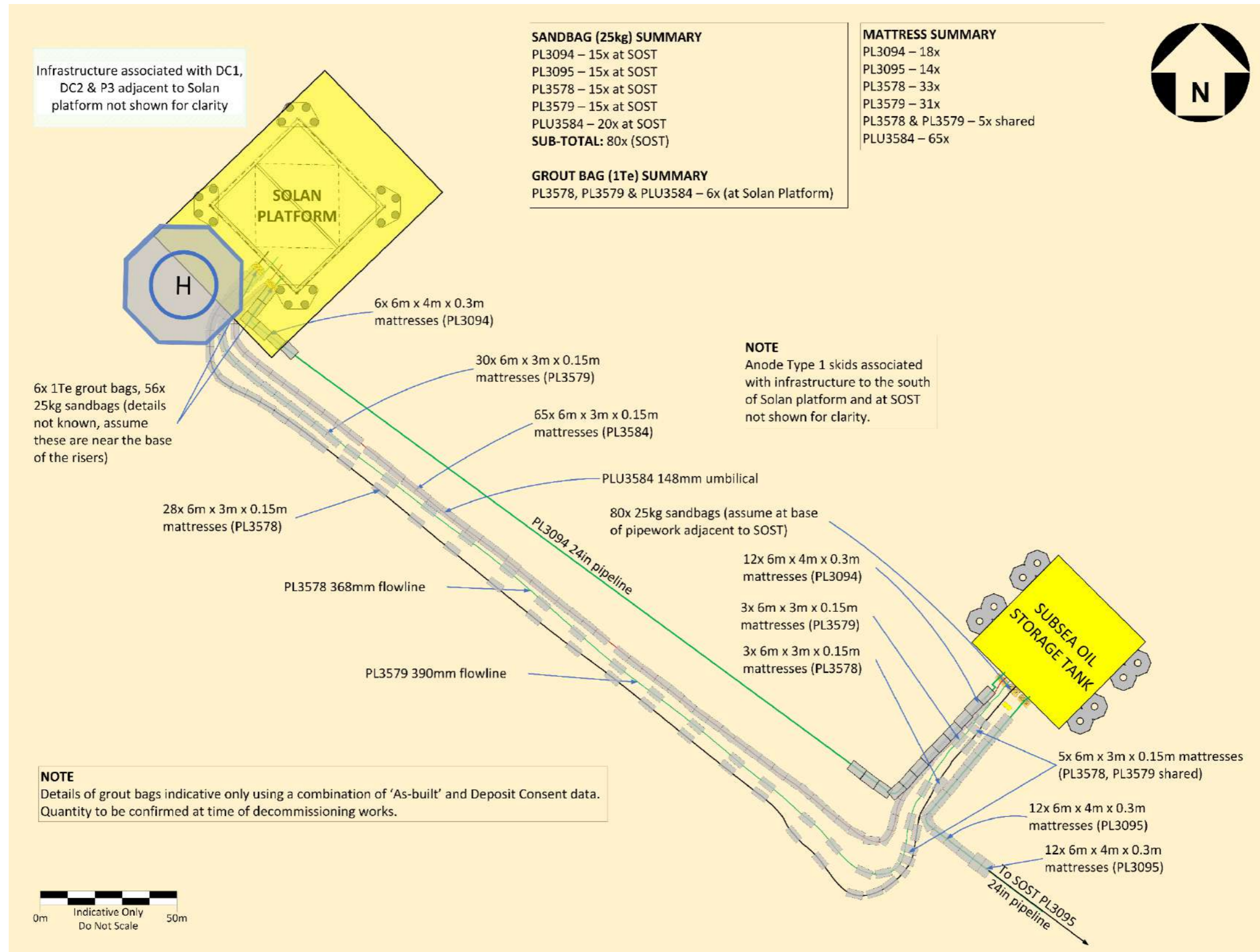


Figure B.3.1: Pipelines, flowlines & umbilicals between Solan platform & SOST

### Appendix B.4 Single Anchor Loading (SAL) approach

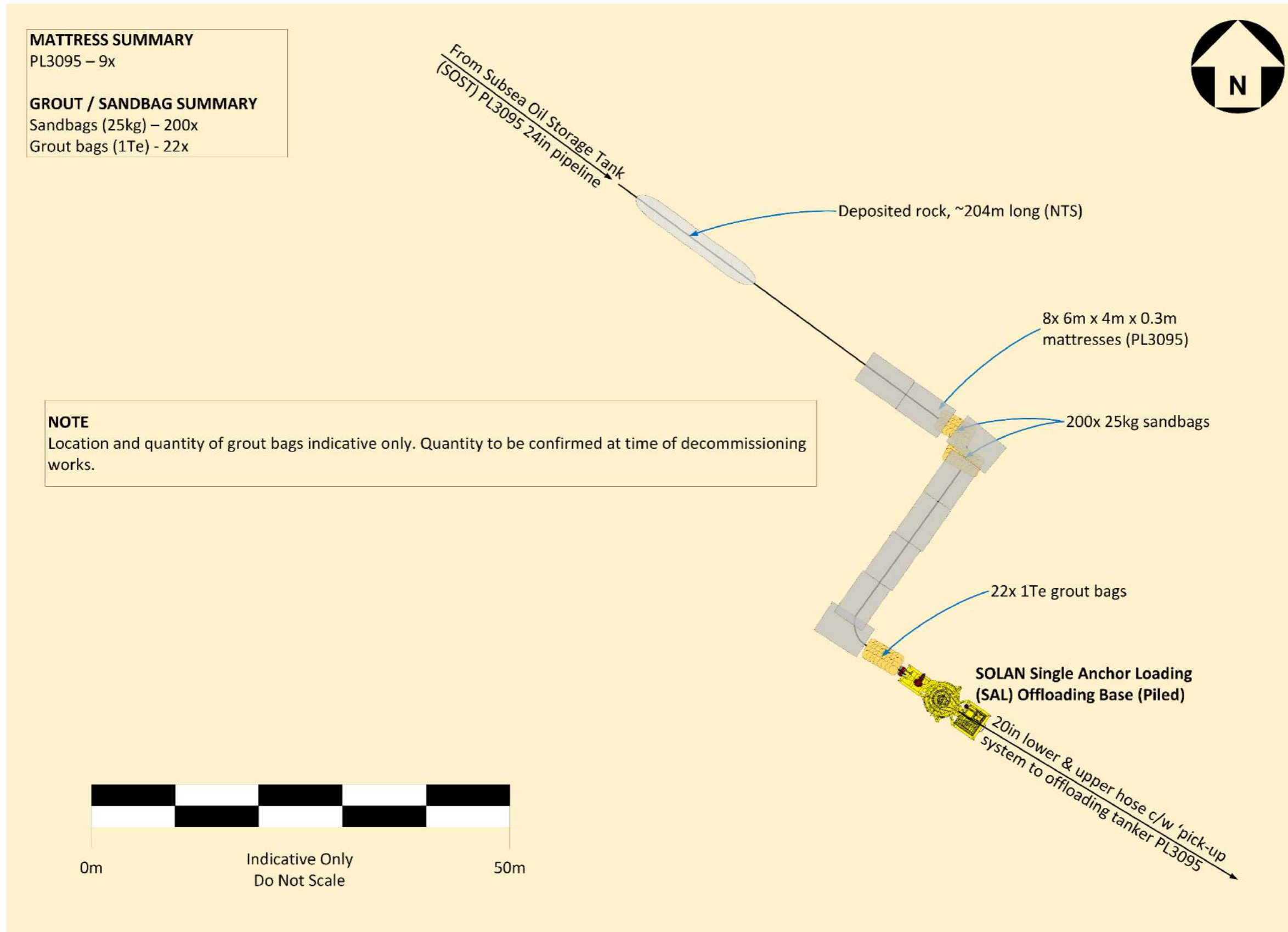
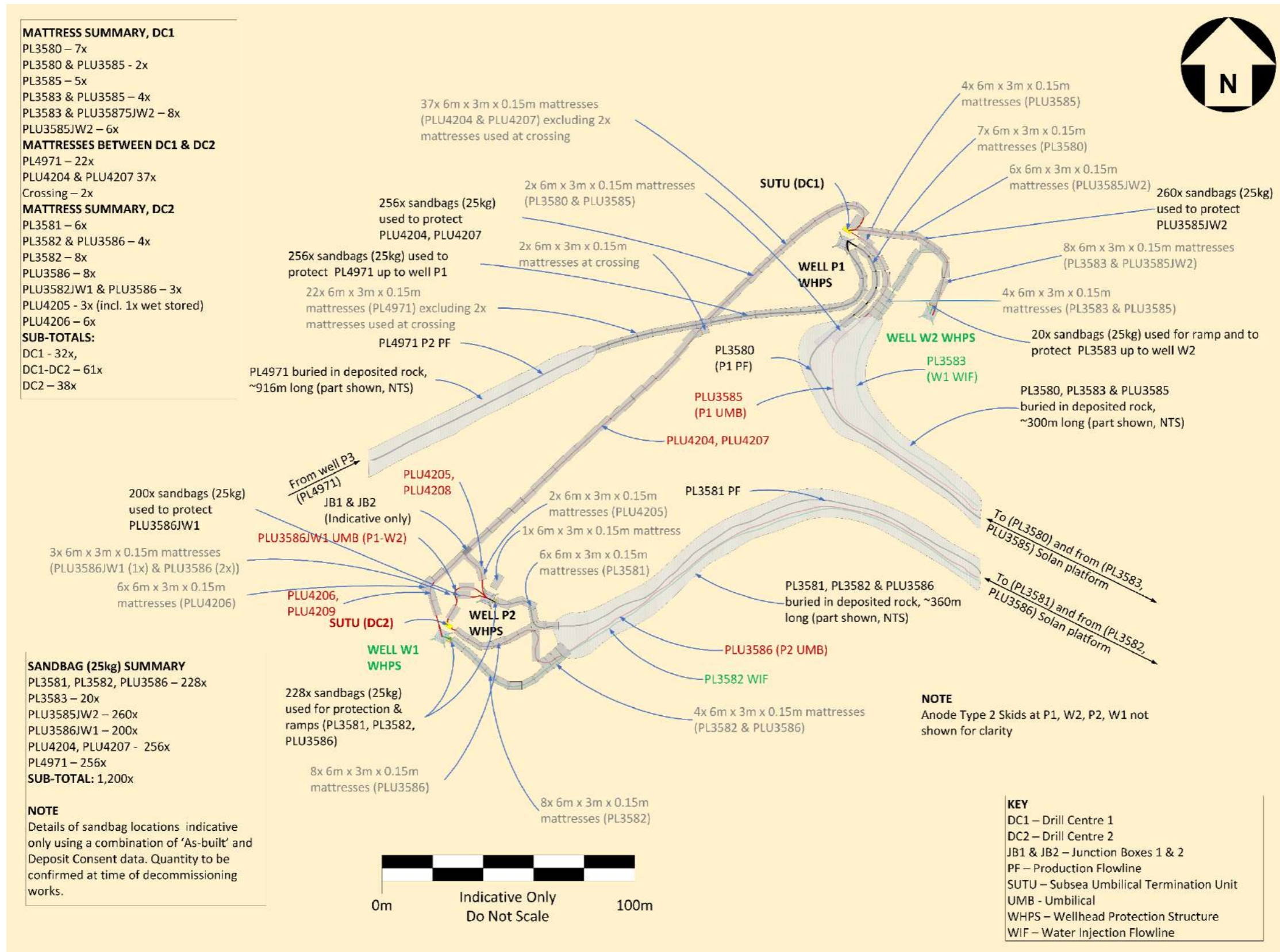


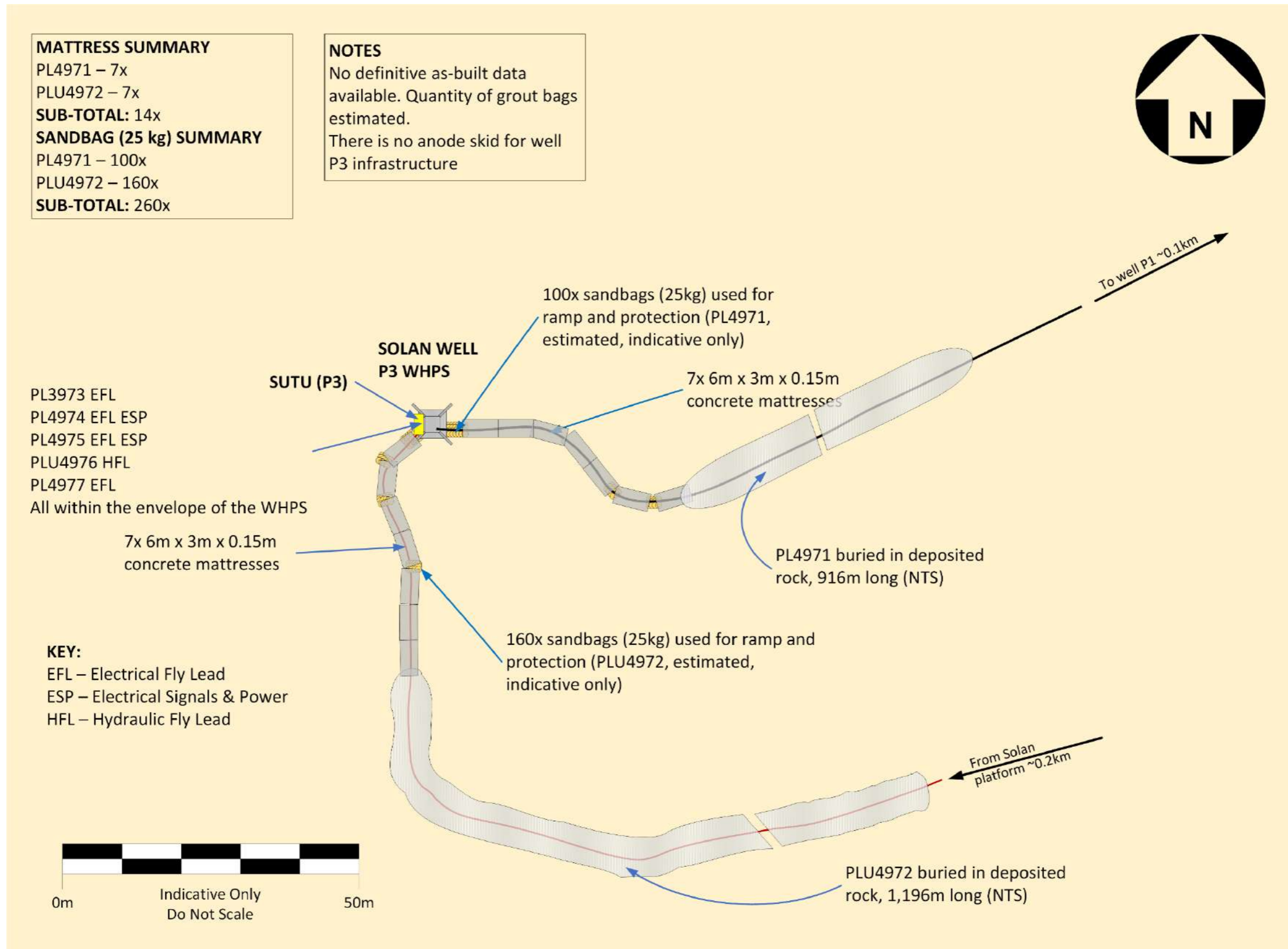
Figure B.4.1: PL3095 at SAL

**Appendix B.5 DC1 (wells P1 & W2) & DC2 (wells P2 & W1)**



**Figure B.5.1: Layout at DC1 (wells P1 & W2) and DC2 (wells P2 & W1)**

**Appendix B.6 Well P3**



**Figure B.6.1: Layout at well P3**

## APPENDIX C PIPELINES C TABLES

### Appendix C.1 Technical Assessment

| Criteria  | Aspect             | Sub-criteria            | PL3095 – technical assessment   |  |
|-----------|--------------------|-------------------------|---|--|
|           |                    |                         | Complete removal  | Leave <i>in situ</i>   |
| Technical | Offshore Execution | Risk of project failure | <p>Part of PL3095 is buried under 204m of deposited rock but otherwise the pipeline is surface laid, partly protected and stabilised using concrete mattresses at the ends.</p> <p>Technically, complete removal of the concrete coated pipeline would be done using the 'cut and lift' method with little threat of project failure.</p> <p>For the full removal option, although excavation using an MFE is tried and tested, compared to the leave in situ option, that excavation needs to take place and the extra length of pipeline removed, which results in a less favourable assessment for complete removal compared to the leave <i>in situ</i> option.</p> | <p>Part of PL3095 is buried under 204m of deposited rock but otherwise the pipeline is surface laid, partly protected and stabilised using concrete mattresses at the ends.</p> <p>Technically, removal of the concrete coated pipeline would be done using the 'cut and lift' method with little threat of project failure.</p> <p>Compared to the full removal option, 204m of the concrete weight coated section of PL3095 would remain <i>in situ</i> buried under rock.</p> |
|           |                    | Technological challenge | Technology is currently available to excavate and 'cut and lift' the pipeline to shore.   | Technology is currently available to and 'cut and lift' the pipeline to shore.   |
|           |                    | Technical challenge     | Removal of PL3095 would require the excavation of 204m of deposited rock with a depth of cover ~2.7m. This would probably involve use of an MFE to disperse the rock. It is possible but unlikely that this would prove problematic. The 'cut and lift' method of removal has been done before.   | Stable and buried pipelines have been buried under rock and left <i>in situ</i> before so this approach would be achievable from a technical perspective.  |
| Technical | Legacy             | Risk of project failure | No pipeline surveys would be required in future.  | Pipeline surveys have been undertaken in the past for large concrete coated pipelines with no issues.  |
|           |                    | Technological challenge | As above.   | The technology is currently available for conducting pipeline surveys.   |
|           |                    | Technical challenge     | As above.   | There should be no technical issues associated with conducting surveys of these pipelines in future.   |

**Table C.1.1: PL3095 - technical assessment**

| Flowlines and umbilicals – technical assessment |                    |                         |   |  |
|---|--------------------|-------------------------|---|--|
| Criteria  | Aspect             | Sub-criteria            | Complete removal  | Leave <i>in situ</i>   |
| Technical                                       | Offshore Execution | Risk of project failure | PL3580, PL3581, PL3582, PL3583, PLU3585, PLU3586, PL4971, PLU4972. Technically, complete removal of the flowlines and umbilicals would most likely be achievable. There is experience in UKCS with reverse reeling flexible flowlines and umbilicals and it would be achievable. The 'cut and lift' would be availability as a contingency for any of the flowlines and umbilicals. Overlying rock would likely be dispersed using an MFE. There is little risk of project failure. | PL3580, PL3581, PL3582, PL3583, PLU3585, PLU3586, PL4971, PLU4972. Technically, the sections of flowlines and umbilicals buried under rock could be left <i>in situ</i> with no risk of project failure. The surface laid sections would likely be removed using 'cut and lift' as they would be too short to be recovered using reverse reel when considering the water depth. There is little risk of project failure. |
|   |                    | Technological challenge | Technology is currently available to excavate, 'cut and lift', or 'reverse reel' the flowlines and umbilicals to shore.   | Technology is currently available to 'cut and lift' short sections of the flowlines and umbilicals to shore.   |
|   |                    | Technical challenge     | Excavation of flowlines and umbilicals buried under rock could prove problematic but will be achievable. The 'reverse reel' method could also be used for recovery of the flowlines and umbilicals with the 'cut and lift' method available as fall a back method of recovery.  | Stable and buried flowlines and umbilicals pipelines have been left <i>in situ</i> before so this approach would be achievable.  |
| Technical                                       | Legacy             | Risk of project failure | No pipeline surveys would be required in future.  | Pipeline surveys have been undertaken in the past although sometimes there can be issues with detectability of umbilicals, as it depends on the amount of steel armour. However, with the right equipment umbilicals can usually be surveyed for depth of burial unless they are buried too deeply.  |
|   |                    | Technological challenge | As above.   | The technology is currently available for conducting flowline and umbilical surveys but it not so effective in detecting smaller umbilicals with less small armour.  |
|   |                    | Technical challenge     | As above.   | Notwithstanding the above, there should be no technical issues associated with conducting pipeline surveys in future.  |

**Table C.1.2: Flowlines and umbilicals - technical assessment**



## Appendix C.2 Safety Assessment

|          |                    |   | PL3095 - Safety assessment  |   |
|----------|--------------------|---|---|---|
| Criteria | Aspect             | Sub-criteria                                    | Complete removal  | Leave <i>in situ</i>  |
| Safety   | Offshore Execution | Health & safety risk offshore project personnel | <p>PL3095. More offshore work than leave <i>in situ</i>. Excavation of the pipeline and recovery using the 'cut and lift' method. The work associated with 'cut and lift' would be repetitive (typically ~80 to ~100 lengths of pipe per km) but manageable from an HSE perspective.</p> <p>The concrete coating may spall as it is being lifted and transferred to the vessel, presenting a particular dropped object hazard to be aware of.</p> <p>With appropriate engineering and pipeline integrity checks and planning the 'reverse reel' method would also be manageable from an HSE perspective.</p> <p>Most of the work could be done using equipment operated remotely and achieved without using divers. Material handling on vessel decks could be automated given the right resources and focus.</p> | <p>PL3095. If it can be assumed that all the surface laid sections would be removed as per mandatory requirements, at most only the short section of PL3095 (204m long) would be left <i>in situ</i> and this would be buried under rock.</p> <p>Therefore, there is little to choose between the complete removal and leave <i>in situ</i> decommissioning options and the threat to project personnel will be largely the same.</p> |
|          |                    | Health & safety risk to mariners                | <p>The surface laid sections of both pipelines are currently located within a 500m safety zone, except for the short 204m long section of PL3095 that is buried under deposited rock. The risk to mariners in the short term would be aligned with the duration the activities would be undertaken in the field. Duration of vessels in the field would be largely the same for both options.</p>   | <p>The surface laid sections of both pipelines are currently located within a 500m safety zone, except for the short 204m long section of PL3095 that is buried under deposited rock. The risk to mariners in the short term would be aligned with the duration the activities would be undertaken in the field. Duration of vessels in the field would be largely the same for both options.</p>                                     |
|          |                    | Safety risk onshore project personnel           | <p>The requirements for off-loading, onshore cutting, lifting, and material handling associated with disposal of the pipelines and the associated threat to the safety of onshore project personnel would be largely the same for both options.</p> <p>The work would all be manageable from an HSE perspective.</p>  | <p>The requirements for off-loading, onshore cutting, lifting, and material handling associated with disposal of the pipelines and the associated threat to the safety of onshore project personnel would be largely the same for both options.</p> <p>The work would all be manageable from an HSE perspective.</p>  |
| Safety   | Legacy             | Health & safety risk offshore project personnel | No pipeline surveys would be required.  | Pipeline surveys may be required, but this activity is considered routine with managed risks.   |
|          |                    | Health & safety risk to mariners                | No infrastructure left <i>in situ</i> therefore no residual snag hazards. Lower threat to safety as potential snag hazards completely removed.  | A short section of PL3095 204m long would be left <i>in situ</i> and this is buried under deposited rock. Theoretically this would present a slightly higher risk to mariners, but it is buried.  |
|          |                    | Safety risk onshore project personnel           | n/a   | n/a   |

Table C.2.1: PL3095 – safety assessment

| Flowlines and umbilicals – safety assessment |                    |   |  |   |
|--|--------------------|---|--|---|
| Criteria                                     | Aspect             | Sub-criteria                                    | Complete removal   | Leave in situ   |
| Safety                                       | Offshore Execution | Health & safety risk offshore project personnel | <p>PL3580, PL3581, PL3582, PL3583, PLU3585, PLU3586, PL4971, PLU4972. More material would be recovered, but the method of recovery would differ from the <i>leave in situ</i> option.</p> <p>Excavation of the flowlines and recovery, using the 'reverse reel' method with the 'cut and lift' method available as contingency. With appropriate engineering and pipeline integrity checks and planning both methods of recovery would be manageable from an HSE perspective.</p> <p>Most of the work would be done using equipment operated remotely and achieved without using divers. Material handling on vessel decks could be automated given the right resources and focus.</p> <p>Taking account of the mandatory requirement to remove surface laid flowlines, pipelines and the associated protection and stabilisation features the difference between the two options from a health &amp; safety perspective reduces.</p> <p>Removal of the protection and stabilisation materials and overlying rock would allow the flowlines and umbilicals to be recovered using 'reverse reel' which means less material handling. This option would be slightly preferable in this instance.</p> | <p>PL3580, PL3581, PL3582, PL3583, PLU3585, PLU3586, PL4971, PLU4972. Excavation of the flowlines and recovery, probably using 'cut and lift' method because of the water depth (~136m) and the shorter lengths of material being recovered.</p> <p>The work associated with 'cut and lift' would be repetitive (typically ~80 to ~100 lengths of pipe per km) but manageable from an HSE perspective.</p> <p>With appropriate engineering and pipeline integrity checks and planning this method of recovery would be manageable from an HSE perspective.</p> <p>Most of the work could be done using equipment operated remotely and achieved without using divers. Material handling on vessel decks could be automated given the right resources and focus.</p> |
|  |                    | Health & safety risk to mariners                | <p>The risk to mariners in the short term would be aligned with the duration of the activities which would be undertaken in the field. Duration of vessels in the field would be slightly less than for <i>leave in situ</i>. Using the 'reverse reel' method would mean that the vessel would be attached to a pipeline and could not move out of the way quickly. Using the 'cut and lift' method would also restrict the ability of a vessel to move out of the way, but for a relatively short time. Overall, there is little to differentiate the options.</p>  | <p>Only the flowline and umbilical ends leading up to the buried sections (under rock) would be dealt with.</p> <p>Because the 'cut and lift' method would probably be used for recovering the ends, it is possible that the vessels would be in the field longer for the <i>leave in situ</i> option. Overall, there is little to differentiate the options.</p>   |
|  |                    | Safety risk onshore project personnel           | <p>Slightly more off-loading, off-reeling, onshore cutting, lifting, and material handling associated with disposal of the flowlines and umbilicals; presents an increased safety risk to personnel.</p> <p>Composite flowlines and umbilicals are not as easy to breakdown as steel pipelines.</p> <p>The work would all be manageable from an HSE perspective. There is nothing to choose between the options.</p>   | <p>Slightly less off-loading, onshore cutting, lifting, and material handling associated with disposal of the flowlines and umbilicals; presents an increased safety risk to personnel. It is unlikely that off-reeling will be required.</p> <p>Composite flowlines and umbilicals are not as easy to breakdown as steel pipelines.</p> <p>The work would all be manageable from an HSE perspective. There is nothing to choose between the options.</p>   |
| Safety                                       | Legacy             | Health & safety risk offshore project personnel | <p>No pipeline surveys would be required.</p>  | <p>Pipeline surveys may be required, but this activity is considered routine with well understood risks.</p>  |
|  |                    | Health & safety risk to mariners                | <p>No infrastructure left in situ therefore no residual snag hazards. Lower risk as potential snag hazards completely removed. Overall, however, there is little to choose between the options.</p>  | <p>Any infrastructure left in situ will be buried under deposited rock, therefore no residual snag hazards will remain. Marginally higher risk as potential snag hazards would remain <i>in situ</i>. Overall, however, there is little to choose between the options.</p>  |
|  |                    | Safety risk onshore project personnel           | n/a  | n/a   |

**Table C.22: Flowlines and umbilicals – safety assessment**

### Appendix C.3 Environmental Assessment

| Environmental assessment |                    |  |   |  |
|--------------------------|--------------------|--|---|--|
| Criteria                 | Aspect             | Sub-criteria   | Complete removal  | Leave <i>in situ</i>   |
| Environmental            | Offshore Execution | Energy & emissions   | PL3095. Energy use and resulting emissions would be related mostly to the amount of time the vessels are working. On this basis, for both the complete removal and leave <i>in situ</i> decommissioning options would be largely the same.  | PL3095. Energy use and resulting emissions for both the complete removal and leave <i>in situ</i> decommissioning options would be largely the same.   |
|                          |                    | Seabed disturbance, area affected  | PL3095. The area of seabed disturbed would be related to the length of pipeline being removed. Even accounting for the dispersal of rock, the area affected (0.024km <sup>2</sup> ) would be slightly larger for the complete removal decommissioning option. Area affected assumes 10m corridor for pipeline and 60m corridor for dispersal of rock 2.7m high. The area of seabed affected is not significant. | PL3095. The area of seabed disturbed would be related to the length of pipeline being removed. The area affected (0.012km <sup>2</sup> ) would be slightly smaller for the leave <i>in situ</i> option. The area of seabed affected is not significant.  |
|                          |                    | Disturbance to Protected Area  | n/a   | n/a  |
|                          |                    | Effect on Water Column: Liquid discharges, Noise   | PL3095. Discharges and releases to the water column are related to the duration of the activities being undertaken. On this basis, for both the complete removal and leave <i>in situ</i> decommissioning options would be largely the same.  | PL3095. Discharges and releases to the water column are related to the duration of the activities being undertaken. On this basis, for both the complete removal and leave <i>in situ</i> decommissioning options would be largely the same.   |
|                          |                    | Waste creation and use of resources such as landfill. Recycling and replacement of materials | The quantity of material recovered (1,521m long) will be slightly larger for the complete removal option. No materials would be lost as no materials would be left <i>in situ</i> .   | The quantity of material recovered will be slightly less than for the complete removal options. A small quantity of material (204m long compared with 1,317m recovered for leave <i>in situ</i> ) would be lost and needs to be replaced as it would be left buried <i>in situ</i> under rock. |
| Environmental            | Legacy             | Energy & emissions   | No pipeline status or burial surveys required.  | Future surveys may be required resulting in energy use and emissions.  |
|                          |                    | Seabed disturbance, area affected  | No pipeline status or burial surveys required.  | The seabed should not be affected by survey work as it is non-intrusive.   |
|                          |                    | Disturbance to Protected Area  | n/a   | n/a  |
|                          |                    | Effect on Water Column: Liquid discharges, Noise   | As above.   | Future surveys may be required. Discharges and releases to the water column are related to the duration of activities being undertaken   |
|                          |                    | Waste creation and use of resources such as landfill. Recycling and replacement of materials | No pipeline status or burial surveys required.  | No related activities would be required.   |

**Table C.3.1: PL3095 – environmental assessment**

| Flowlines and umbilicals – environmental assessment |                    |  |   |  |
|---|--------------------|--|---|--|
| Criteria  | Aspect             | Sub-criteria   | Complete removal  | Leave <i>in situ</i>   |
| Environmental                                       | Offshore Execution | Energy & emissions   | <p>PL3580, PL3581, PL3582, PL3583, PLU3585, PLU3586, PL4971, PLU4972. Overall, energy use and resulting emissions for this option would be comparable to the leave <i>in situ</i> option.</p> <p>Once the protection and stabilisation materials have been recovered and the rock dispersed the flowlines and umbilicals would likely be recovered using reverse reel which would take less time than for 'cut and lift' for the surface laid ends.</p> <p>Except for the steel components the type of material involved is such that energy and emissions would be needed to manufacture the composite components. Experience suggests that it is unlikely that the flowlines and umbilicals would be reused 'as is'. The steel would be recycled whereas the composite materials would likely be recycled as recovered energy.</p> <p>Overall, there would be little to choose between the options.</p> | <p>PL3580, PL3581, PL3582, PL3583, PLU3585, PLU3586, PL4971, PLU4972. Overall, energy use and resulting emissions for this option would be comparable to the leave <i>in situ</i> option.</p> <p>Because the 'cut and lift' method would probably be used for recovering the ends, it is possible that the vessels would be in the field for longer for the leave <i>in situ</i> option.</p> <p>Except for the steel components the type of material involved is such that energy and emissions would be needed to manufacture the composite components. Experience suggests that it is unlikely that the flowlines and umbilicals would be reused 'as is'. The steel would be recycled whereas the composite materials would likely be recycled as recovered energy.</p> <p>Overall, there would be little to choose between the options.</p> |
|   |                    | Seabed disturbance, area affected  | The amount of seabed disturbed would be related to the length of product being removed and would also involve the dispersal of rock. Assuming a 10m wide corridor is affected, and the existing rock cover would be dispersed over a 30m wide corridor, the area of seabed impacted (0.12km <sup>2</sup> ) by recovery operations would be largest for this option. In general terms, the area impacted is still small.   | The amount of seabed disturbed would be related to the length of product being removed and would also involve the dispersal of rock. Assuming a 10m wide corridor is affected, the area of seabed impacted (0.01km <sup>2</sup> ) by recovery operations would be least for this option.   |
|   |                    | Disturbance to Protected Area  | n/a   | n/a  |
|   |                    | Effect on Water Column: Liquid discharges, Noise   | Discharges and releases to the water column are related to the duration of activities being undertaken and counterintuitively the duration of activities should be slightly less for the complete removal option.   | Discharges and releases to the water column are related to the duration of activities being undertaken and counterintuitively the duration of activities would be slightly more for leave <i>in situ</i> .   |
|   |                    | Waste creation and use of resources such as landfill. Recycling and replacement of materials | Except for the steel components the type of material involved is such that energy (and resulting emissions) would be needed to manufacture the composite components. Experience suggests that it is unlikely that the flowlines and umbilicals would be reused 'as is'. The steel would be recycled whereas the composite materials would likely be recycled as recovered energy. Combined length recovered would be ~6.0km. More composite material would be recovered for the complete removal option.  | Except for the steel components the type of material involved is such that energy and emissions would be needed to manufacture the composite components. Experience suggests that it is unlikely that the flowlines and umbilicals would be reused 'as is'. The steel would be recycled whereas the composite materials would likely be recycled as recovered energy. Combined length recovered ~3.2km. Less composite material would be recovered for the leave <i>in situ</i> option.  |
| Environmental                                       | Legacy             | Energy & emissions   | No pipeline status or burial surveys required.  | It can be expected that future surveys would be required.  |
|   |                    | Seabed disturbance, area affected  | A larger area of seabed (0.095km <sup>2</sup> ) would be permanently impacted because of the dispersal of rock to allow the flowlines and umbilicals to be recovered. For the purposes of this assessment, it is assumed that the area permanently disturbed would be 30m wide pipeline corridor along the existing length of rock.   | The area permanently impacted would be limited to the area of deposited rock (0.032km <sup>2</sup> ) being left <i>in situ</i> .   |
|   |                    | Disturbance to Protected Area  | n/a   | n/a  |
|   |                    | Effect on Water Column: Liquid discharges, Noise   | No pipeline status or burial surveys required.  | It can be expected that future surveys would be required.  |
|   |                    | Waste creation and use of resources such as landfill. Recycling and replacement of materials | No activity required.   | No activity required.  |

**Table C.3.2: Flowlines and umbilicals – environmental assessment**

## Appendix C.4 Societal Assessment

| PL3095 – societal assessment |                    |                                    |   |   |
|------------------------------|--------------------|------------------------------------|---|---|
| Criteria                     | Aspect             | Sub-criteria                       | Complete removal  | Leave <i>in situ</i>  |
| Societal                     | Offshore Execution | Effect on commercial activities    | The impact of decommissioning vessel traffic on local commercial activities such as fishing would be largely the same for both the complete removal and leave <i>in situ</i> decommissioning options. | The impact of decommissioning vessel traffic on local commercial activities such as fishing would be largely the same for both the complete removal and leave <i>in situ</i> decommissioning options. |
|                              |                    | Employment                         | The impact of decommissioning activities on employment would be marginally higher for the complete removal option.  | The impact of decommissioning activities on employment would be marginally less for the leave <i>in situ</i> option.  |
|                              |                    | Communities or impact on amenities | The impact of decommissioning activities on communities or amenities would be marginally higher for the complete removal option.  | The impact of decommissioning activities on port related activities would be marginally less for the leave <i>in situ</i> option.   |
| Societal                     | Legacy             | Effect on commercial activities    | No impact as no legacy related activities would be required. Largely the same for both decommissioning options.   | No impact as no legacy related activities would be required. Largely the same for both decommissioning options.   |
|                              |                    | Employment                         | No future opportunities for continuation of employment.   | Marginal opportunity for continuation of employment.  |
|                              |                    | Communities or impact on amenities | No opportunities for continuity of work in ports and disposal sites. Largely the same for both decommissioning options.   | No opportunities for continuity of work in ports and disposal sites. Largely the same for both decommissioning options.   |

**Table C.4.1: PL3095 – societal assessment**

| Flowlines and umbilicals – societal assessment |                    |                                    |   |   |
|--|--------------------|------------------------------------|---|---|
| Criteria                                       | Aspect             | Sub-criteria                       | Complete removal  | Leave <i>in situ</i>  |
| Societal                                       | Offshore Execution | Effect on commercial activities    | PL3580, PL3581, PL3582, PL3583, PLU3585, PLU3586, PL4971, PLU4972. Impact of decommissioning vessel traffic on local commercial activities such as fishing would be comparable for both options. There is little to choose between the options. | PL3580, PL3581, PL3582, PL3583, PLU3585, PLU3586, PL4971, PLU4972. Impact of decommissioning vessel traffic on local commercial activities such as fishing would be comparable for both options. There is little to choose between the options. |
|  |                    | Employment                         | The impact of decommissioning activities on employment would be marginally higher for the complete removal option.  | The impact of decommissioning activities on employment would be marginally less for the leave <i>in situ</i> option.  |
|  |                    | Communities or impact on amenities | The impact of decommissioning activities on communities or amenities would be marginally higher for the complete removal option.  | The impact of decommissioning activities on port related activities would be marginally less for the leave <i>in situ</i> option.   |
| Societal                                       | Legacy             | Effect on commercial activities    | No impact as no legacy related activities would be required. Largely the same for both decommissioning options.   | No impact as no legacy related activities would be required. Largely the same for both decommissioning options.   |
|  |                    | Employment                         | No future opportunities for continuation of employment.   | Marginal opportunity for continuation of employment.  |
|  |                    | Communities or impact on amenities | No opportunities for continuity of work in ports and disposal sites. Largely the same for both decommissioning options.   | No opportunities for continuity of work in ports and disposal sites. Largely the same for both decommissioning options.   |

**Table C.4.2: Flowlines and umbilicals - societal assessment**

## Appendix C.5 Cost Assessment

| PL3095 – cost assessment |                    |              |   |  |
|--------------------------|--------------------|--------------|---|--|
| Criteria                 | Aspect             | Sub-criteria | Complete removal  | Leave <i>in situ</i>   |
| Cost                     | Offshore Execution | PL3095       | PL3095. Complete removal would be the most expensive option, but the cost would be less than twice the cost of the leave <i>in situ</i> option. | PL3095. The leave <i>in situ</i> option would cost less than the complete removal option, even accounting for future legacy surveys. |
| Cost                     | Legacy             | PL3095       | No legacy surveys would be required.  | Legacy surveys could potentially be required to monitor the section of pipeline buried under rock.                                   |

**Table C.5.1: PL3095 – cost assessment**

| Flowlines and umbilicals – cost assessment |                    |                        |   |   |
|--|--------------------|------------------------|---|---|
| Criteria                                   | Aspect             | Sub-criteria           | Complete removal  | Leave <i>in situ</i>  |
| Cost                                       | Offshore Execution | Flowlines & umbilicals | PL3580, PL3581, PL3582, PL3583, PLU3585, PLU3586. It would cost less to completely remove these pipelines than it would be to leave them <i>in situ</i> . This is because once the protection and stabilisation features have been removed and the overlying rock dispersed, the products could be recovered using 'reverse reel' which is a more efficient method than 'cut and lift'.   | PL3580, PL3581, PL3582, PL3583, PLU3585, PLU3586. It would cost less to completely remove the infrastructure rather than leave <i>in situ</i> . This is because once the protection and stabilisation features have been removed and the overlying rock dispersed, the products could be recovered using reverse reel which is a more efficient method than 'cut and lift'. |
|  |                    |                        | PL4971 & PLU4972. It would cost slightly more to completely remove the infrastructure rather than leave <i>in situ</i> . This is because once the protection and stabilisation features have been removed and the overlying rock dispersed, the products could be recovered using reverse reel which is a more efficient method than 'cut and lift'. The reason for PL4971 & PLU4972 costing slightly more is because there would be a relatively short length of product and few mattresses to be recovered at the ends. | PL4971 & PLU4972. It would cost slightly less to leave these <i>in situ</i> .   |
| Cost                                       | Legacy             | Flowlines & umbilicals | Should the pipeline(s) have been completely removed no legacy pipeline burial surveys would be required in future.  | Future burial surveys will be required. For the purposes of the assessment, it is assumed that 3x legacy pipeline surveys would be required.  |

**Table C.5.2: Flowlines and umbilicals - cost assessment**

## APPENDIX D PIPELINE COST ASSESSMENT

### Appendix D.1 Overview

The following section details the qualitative comparative assessment made to distinguish the decommissioning options. Note that the figures quoted do not account for the overall costs of decommissioning the pipelines – they only account for the difference in cost once activities common to both options have been discounted.

The costs have been normalised relative to the cheapest option and categorised as indicated in Table D.1.1.

| High / Intolerable & not acceptable                  | Medium / Tolerable non-preferred | Low/Broadly acceptable & most preferred | Low/Broadly acceptable but least preferred |
|--|----------------------------------|---|--|
| More than 10x (order of magnitude) the cheapest cost | More than 2x the cheapest cost   | Cheapest cost                           | Less than 2x more than cheapest cost       |

**Table D.1.1: Categories of impact – cost assessment**

### Appendix D.2 Assumptions

The following key assumptions have been used in the cost by difference assessment:

- Operator and contractor management and engineering costs are excluded on the basis that this cost would be incurred whichever decommissioning option would be pursued.
- PL3095 would be completely removed using the ‘cut and lift’ method.
- For the complete removal option, flexible flowlines and umbilicals would be removed using the reverse reel method assuming that their integrity could be assured. For the purposes of the assessment, it is assumed that the recovery vessel would transport one pipeline reel at a time.
- For the leave *in situ* option, a combination of water depth and pipeline length means that the surface laid sections of the flexible flowlines and umbilicals would be removed using the ‘cut and lift’ method.
- Complete removal costs relate to complete recovery of the pipelines to shore as well as the mattresses and includes the cost of 1x survey following completion of decommissioning.
- Leave *in situ* costs relate to the cost of recovering the surface laid pipeline ends and mattresses on approach to the installations and includes the cost of 1x post decommissioning survey and 3x legacy pipeline surveys in areas where pipelines buried under rock would remain *in situ*.
- All activities could be achieved using remotely operated equipment guided by ROVs. No diving related activities would be required.
- All pipeline and recovery operations could be achieved using a subsea support vessel or similar, supported by the necessary equipment spreads such as ROVs, excavation tools, hydraulic shears, mattress recovery equipment, etc. The services of a pipelay vessel would not be required.
- Port calls have been accounted for on the basis that a vessel needs to transit to port to offload materials recovered from the seabed.
- Given the location, NPT on marine operations is taken as 20%.
- No allowance has been made for the deposition of small quantities of rock on cut pipeline ends; it may not be required, and these costs are unlikely to be significant.
- No account has been made for efficiency. For example, to an extent it might be possible to reduce the number of port calls by using a cargo barge in the field. However, any advantages of this approach would need be offset by the need for appropriate weather conditions and transit tugs.

- For surveys it has been assumed that 1x post decommissioning pipeline survey would be required for each pipeline, and 3x legacy pipeline surveys for those instances where a pipeline or part thereof would be left *in situ* following completion of decommissioning activities. The legacy survey requirement would be based on risk assessments following post-decommissioning surveys and would typically be documented in the close out report.
- The costs associated with mobilisation and demobilisation of survey vessels is excluded since it is not a differentiator, and because mobilisation and demobilisation costs would be incurred for the overall survey activity, not just for one pipeline.



**Appendix D.3 Cost by Difference Table**

| PL ID   | PL Type(s) | Mattresses | Rock (m) | PL End Removal Length | Complete Removal Length | Surface Laid Removal (Leave <i>In situ</i> ) | Complete PL Removal | Surface Laid Removal (Leave <i>In situ</i> ) (Normalised) | Complete PL Removal (Normalised) |
|---------|------------|------------|----------|-----------------------|-------------------------|--|---------------------|---|----------------------------------|
| PL3095  | 24"CWC     | 22         | 204      | 1,317                 | 1,521                   | £1.062                                       | £1.532              | 3.47  | 5.00                             |
| PL3580  | 268mm      | 9.5        | 300      | 238                   | 538                     | £0.125                                       | £0.115              | 5.00  | 4.61                             |
| PL3581  | 268mm      | 4          | 360      | 236                   | 596                     | £0.112                                       | £0.112              | 5.00  | 4.98                             |
| PL3582  | 268mm      | 4          | 360      | 252                   | 612                     | £0.117                                       | £0.114              | 5.00  | 4.88                             |
| PL3583  | 268mm      | 12.5       | 300      | 277                   | 577                     | £0.147                                       | £0.127              | 5.00  | 4.31                             |
| PLU3585 | 176mm      | 10         | 300      | 238                   | 538                     | £0.120                                       | £0.102              | 5.00  | 4.26                             |
| PLU3586 | 176mm      | 3          | 360      | 234                   | 594                     | £0.101                                       | £0.093              | 5.00  | 4.65                             |
| PL4971  | 244mm      | 31         | 916      | 181                   | 1,097                   | £0.162                                       | £0.265              | 3.07  | 5.00                             |
| PLU4972 | 205mm      | 19         | 1,196    | 267                   | 1,463                   | £0.164                                       | £0.255              | 3.21  | 5.00                             |

**NOTES:**

1. The leave *in situ* option assume that the surface laid ends have been removed to where they enter burial in rock, and that the protection and stabilisation features have also been removed. Assumes the surface laid ends would be recovered using the 'cut and lift' method.
2. Complete removal: pipelines with CWC – 'cut & lift', individual pipelines, flowlines, and umbilicals – 'reverse reel', surface laid end sections - 'cut & lift' or 'reverse reel' if possible.
3. The assessment assumes 1x post decommissioning survey would be required irrespective of the decommissioning options, and 3x legacy surveys would be required for parts of any pipelines being left *in situ*.

**Table D.3.1: Pipeline cost by difference assessment (& normalised)**